

This is new in Plant Design 2020 for SOLIDWORKS

The 2020 version of Smapp3D Plant Design also contains many enhancements and improvements in functionality and application.

Contents:

- [General news](#)
- [P&ID](#)
- [Component Wizard](#)
- [Parts Management](#)
- [3D Piping](#)
- [Pipe Specification Editor](#)
- [P&ID To-Do List](#)
- [Isometric](#)

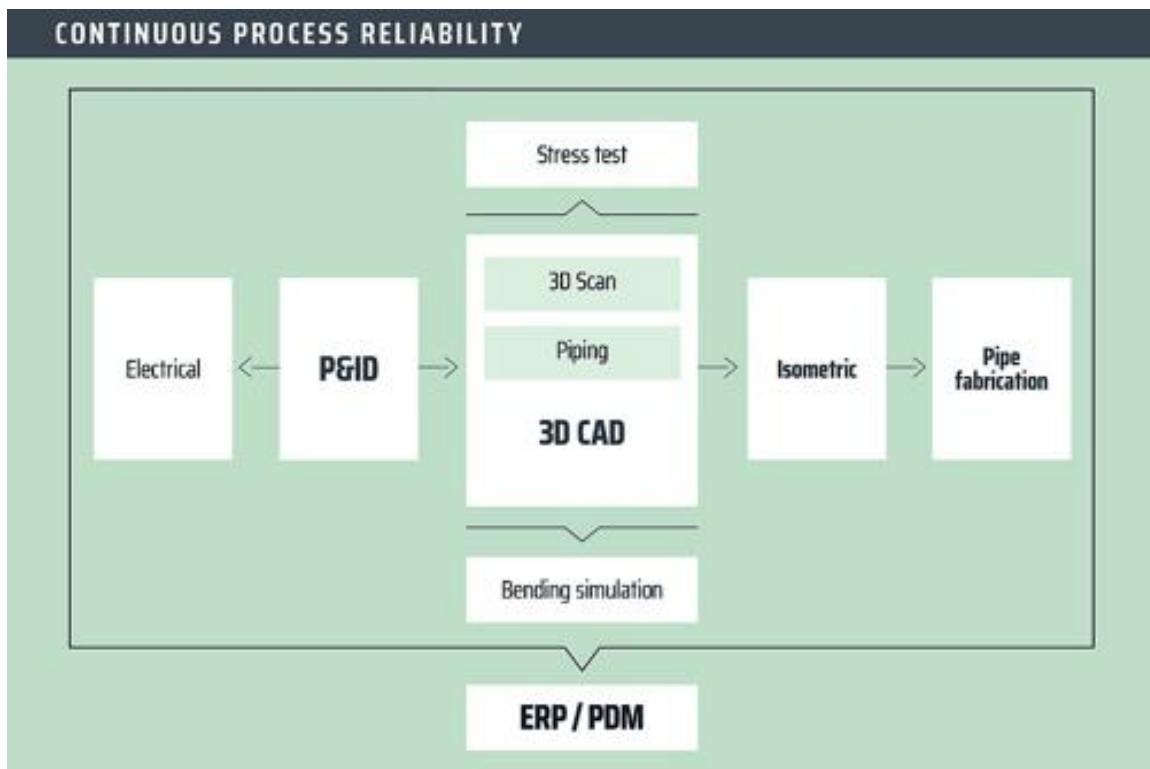

Table of Contents

GENERAL IMPROVEMENTS	4
SUPPORTED CAD VERSIONS	4
ONLINE HELP AVAILABLE	5
LICENSING AND PRODUCT LICENSES REQUIRED IN VERSION 2020	7
STANDARD COLOR SCHEME CHANGED TO OFFICE 2016	7
BUTTONS "INSTALL TOOLBARS" NO LONGER AVAILABLE/NECESSARY	8
AUTOMATIC LOG FILE GENERATION DURING INSTALLATION	8
NEW IN SMAP3D P&ID	9
AUTOMATIC READING AND CHANGING OF OBJECT PROPERTIES	9
NEW DEFAULT BEHAVIORS AT FUNCTION "REPLACE SYMBOL"	10
IMPROVED FUNCTION WHEN WORKING WITH PIPING PIPE SPECIFICATIONS.....	13
NEW DYNAMIC CONNECTION LINE AT PCE SYMBOLS	17
NEW FUNCTIONS FOR COLORING P&ID OBJECTS	19
FILTER FUNCTION IN OBJECT LISTER	24
FORMULA EDITOR FOR SYMBOL DATA FIELDS.....	25
NEW LIST TYPE CONNECTIONS LIST	26
EXCEL TEMPLATE FOR LIST EXPORTS USABLE	28
NEW DISPLAY GROUPING FOR SYMBOL DATA FIELDS	29
NEW SYMBOL DATA FIELDS "DESCRIPTION"	33
NEW DATA FIELD "THUMBNAILS FIELD" FOR DATA SHEETS AND LISTS	35
NEW FUNCTION ASSIGN FOR "READ COMPONENTS LIST"	36
NEW MODULE "CREATE ZIP PACKAGE OF LINKED FILES"	38
NEW BACKLINK FROM UNIT PAGES TO SYMBOL ON DIAGRAM PAGES.....	39
CONFIGURABLE DISPLAY IN ACCESSORY TAB.....	40
ENHANCED COMMAND LINE PARAMETERS FOR PDF EXPORT	41
MESSAGE DISPLAY WHEN PRO FILE IS WRITE-PROTECTED.....	42
SYMBOL DATA FIELDS FROM DATABASE WRITE-PROTECTED	42
LINE PRIORITY NOW ALSO IN QUICK INFO WINDOW OF A LINE.....	43
NEW SETTING FOR INDIVIDUAL TEXT WIDTH AT TEXT PROPERTIES	43
NEW OPTION TO SWITCH OFF ARROWS ON LEADER LINES.....	44
NEW FRENCH LANGUAGE FOR USER INTERFACE	44
IMPROVED ZOOM AND PAN PERFORMANCE	44
OTHER SMALL ENHANCEMENTS/CHANGES:	45
NEW IN COMPONENT WIZARD	46
NEW OPTION TO REGISTER DIRECTLY IN PART FINDER DATABASE.....	46
NEW IN SMAP3D PARTS MANAGEMENT	48
PARTS MANAGEMENT ADMINISTRATOR AND PLANT DESIGN ADMINISTRATOR LOADED TOGETHER IN ONE DIALOG	48
DATABASE ADMINISTRATOR CAN BE STARTED DIRECTLY FROM PART FINDER	49
PARTS MANAGEMENT UPDATES PHYSICAL PROPERTIES DURING GENERATION	50
SUPPORT FOR MICROSOFT SQL SERVER 2017 AND MICROSOFT SQL SERVER 2019	52

NEW IN SMAP3D PIPING.....	53
NEW QUICKPLACE METHOD GROOVED COUPLING.....	53
NEW QUICKPLACE METHOD CLAMP	54
NEW QUICKPLACE METHODS FOR TUBE FITTINGS	55
BUTTONS AND TEXTS RENAMED TO CONCENTRIC REDUCER.....	60
OPTION TO CREATE CUSTOM PIPE TEMPLATE.....	60
SHAPE PIPES CAN NOW ALSO BE PLACED BY FILE SYSTEM PROVIDER.....	60
IMPROVED ALGORITHM FOR ADD-ON PARTS IN REDUCED PIPELINE SITUATIONS	61
API COMMAND TO RENAME PIPELINE PATH NAMES FROM "EXTERNAL"	62
NEW IN PIPE SPECIFICATION EDITOR	63
NEW KEY NAME GROOVED COUPLING	63
NEW KEY NAME CLAMP.....	64
NEW KEY NAMES FOR TUBE FITTINGS.....	65
NEW OPTION TO CONTROL THE STANDARD SETTING FOR "USE FAVORITES"	68
NEW IN THE P&ID TO-DO LIST.....	69
REDESIGN OF ANALYSIS ALGORITHMS WHEN LOADING PRO FILES.....	69
FURTHER NEWS IN TO-DO LIST	71
NEW IN SMAP3D ISOMETRIC	75
SUPPORT OF THE ISOGEN FUNCTION REVISION CLOUDS	75
SUPPORT OF THE ISOGEN WELD ATTRIBUTES	78
SUPPORT OF PDF OUTPUT ACCORDING TO ISOGEN STYLE SETTINGS.....	79
NEW CUSTOM CAD PROPERTY "IGNOREINISOMETRIC" TO IMPROVE READING PERFORMANCE.....	80
IMPRINT	81

General improvements

Supported CAD versions

SOLIDWORKS

The release version of Smap3D Plant Design 2020 supports:

- **SOLIDWORKS 2019 with Service Pack 4 or later**
- **SOLIDWORKS 2020 with Service Pack 0 or later**

Online help available

For all **Smap3D Plant Design programs** (except P&ID, Electrical, and ScanToCAD), in addition to the local help file (*.CHM in the installation directory), the help is now also available online.

This means that a user always has the latest version of the help available and we can extend, correct and provide the help faster and easier with missing content for you.

For the **Parts Management programs**, Online help will be available **from service pack 1**.

User feedback on each online chapter available and welcome!

In order to continuously expand and improve our help(s), we have added the possibility to leave feedback or suggestions for improvement on the respective topic for each chapter of the online help.



Was this page helpful?

Yes

No

If not, what information do you miss here?

Confirm

Language:  

www.Smap3D-plant-design.com

Basic setting in Plant Design Administrator

In the Plant Design Administrator, you can define for your company which **source of help** users should use as soon as they press the F1 key in one of the Plant Design applications or call the help from the menu.

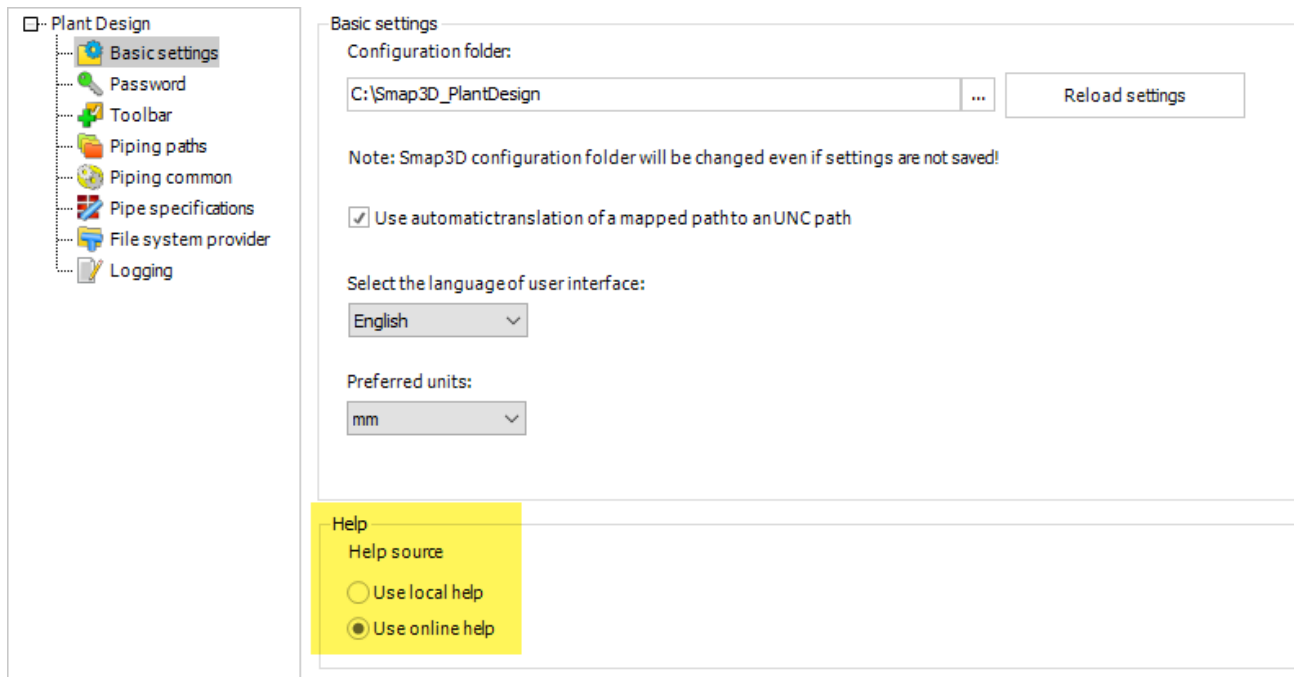

Licensing and product licenses required in version 2020

With Smapp3D Plant Design 2020, the licensing software (License Client Manager and License Server Manager) must also be updated to version 2020 of the CAD-Partner Licensing.

For existing license server installations of CAD-Partner Licensing 2019, the **Plant Design 2020 setup must be installed in License Server mode**.

This will upgrade an existing installation from License Server Manager 2019 to version 2020. The updated License Server Manager 2020 version number will then be **5.20.0.20**.

All local License Client Managers must be uninstalled along with Plant Design 2019 (or previous) applications before the new Plant Design 2020 installation can run for the client computers.

Standard color scheme changed to Office 2016

The **Office 2016** color scheme is now set as the new standard for the program windows and dialogs after installation.

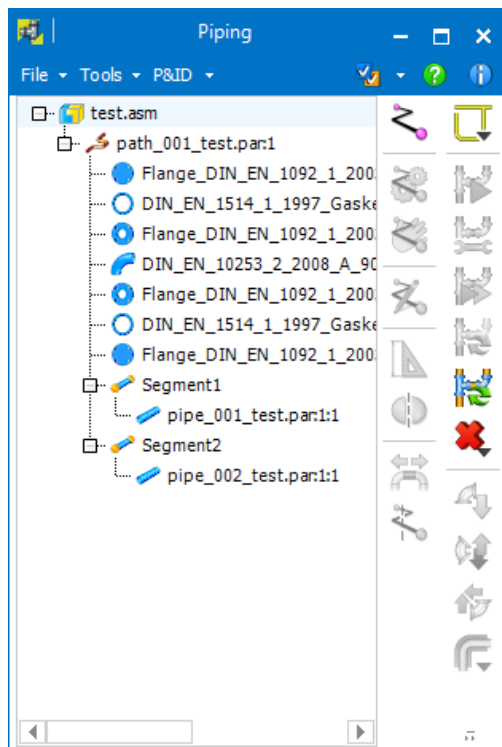

Buttons "Install toolbars" no longer available/necessary

In **Parts Management Administrator** and **Plant Design Administrator** programs, the **Install toolbars** button was previously available in the **Toolbar** tab.

These buttons have been removed because the installation of the toolbar add-ins into the CAD System (according to the checkmark in the corresponding table) is now performed automatically when a user/administrator clicks the **Save** button on the respective toolbar.

Automatic log file generation during installation

Since the hardware and software combinations of the computers on which Smapp3D Plant Design is installed, are becoming more and more complex, from version 2020 onwards our installation routine will always automatically generate log files.

After installation, the storage path of these log files is always in the directory **[ProgramData]\CAD_Partner_GmbH\SetupLogs**.

New in Smap3D P&ID

Automatic reading and changing of object properties

With P&ID 2020, an option for automatic reading and transfer of object properties (lines and symbols) has been implemented.

This new automation is activated by default.

To change/deactivate this, the **Transfer automatically** option (list menu to the right of the **transfer properties** button) must be unchecked.

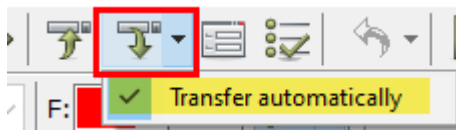

Now all object properties are displayed directly in the P&ID toolbar after selecting/clicking an object (previously only by holding down the "Shift" key while selecting or clicking the **Copy properties** button after selection).

Changes to the displayed object properties in the toolbar are now transferred directly to the object (previously only by clicking the **Transfer properties** button).

New default behaviors at function "Replace Symbol"

With the previous standard behavior of the **Replace Symbol** function in diagrams, there were still function restrictions in the software for some customer-specific use cases.

With P&ID 2020, these were removed, and the **Replace Symbol** function was made much more powerful.

Regarding Symbol data fields

If symbol data fields with filled in values were previously present in a diagram symbol, these were only transferred correctly and completely to the new symbol during replacement, if the new symbol was already **in the symbol library prepared with the 100% identical symbol data fields**.

As a new and enhanced default behavior for this use case, all symbol data fields with filled values of the old symbol is now automatically transferred and added to the symbol data fields of the new symbol, even if they are not prepared in the new symbol.

This prevents the loss of completed information when symbols with different symbol data field definitions are replaced.

New button Database

Previously, only diagram symbols could be replaced with other symbols from the symbol library using the **Replace Symbol** function (button Select...).

Existing article information (from the database) was transferred from the existing symbol to the new symbol, even if this may no longer have made sense (e.g. symbol of a heat exchanger is replaced with the symbol of a pump).

For a user, the correction of the article information at the new symbol was then a necessary manual step.

Since more and more customers are maintaining and saving the assignment between article information and symbol display in their P&ID database, we have added the button **Database** in the **Replace Symbol** dialog.

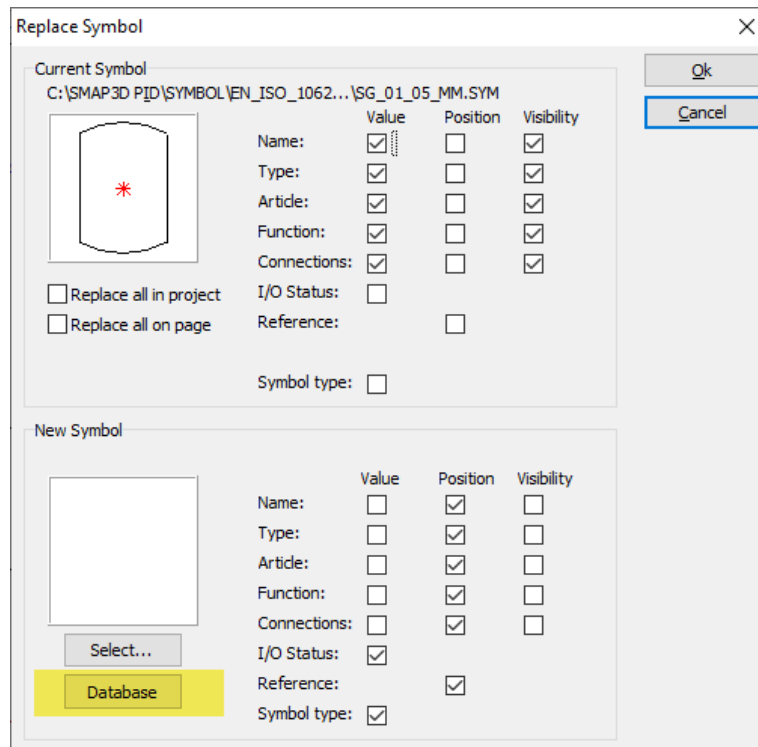

When a user clicks the **Database** button, the user dialog for the P&ID database opens.

With the known functions, the desired new component is selected (based on the article information).

The required P&ID symbol must be assigned to the selected data record in order to be displayed in the **New Symbol** section.

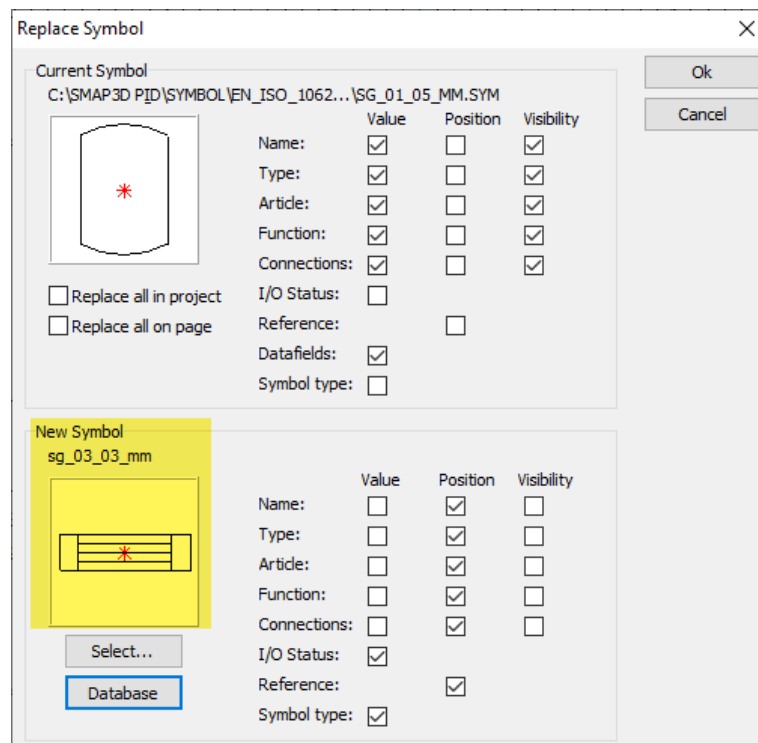

Click **Ok** to perform the replacement.

Better than with the function "Select...", the previous symbol is replaced with the new symbol, at the same time the selected new article information is also transferred to the new symbol. Manual reworking of the article information is no longer necessary!

Object group definition is retained during replacement

If a diagram symbol that was previously assigned to an object group was replaced, the object group information was lost during replacement and the new symbol had to be added separately to the object group again.

This behavior has been changed so that existing object group information on the old symbol is retained after the replacement of a new symbol.

Improved function when working with Piping pipe specifications

Since many versions, the function **Get specifications from Smapp3D Piping** is available when creating pipes/lines in a P&ID diagram.

This allows P&ID users to use stored information from existing Smapp3D Piping pipe specifications for the line data (size and pipe spec) to automatically fill them in.

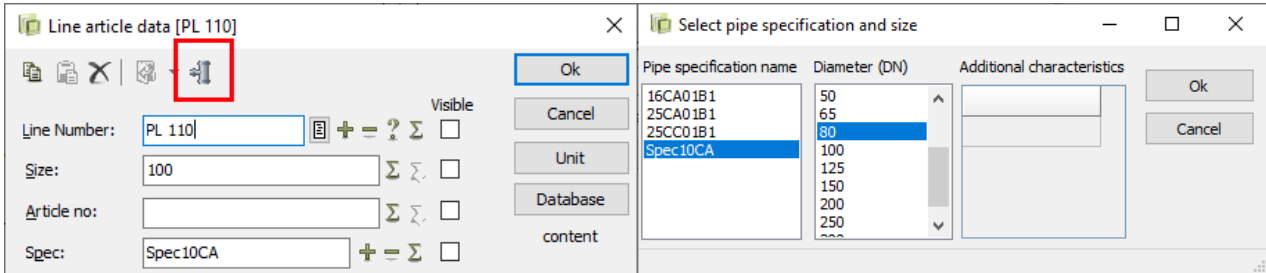

For all pipes/lines defined this way, users can use the **Place from specifications** function to place the appropriate components defined in the respective pipe specifications.

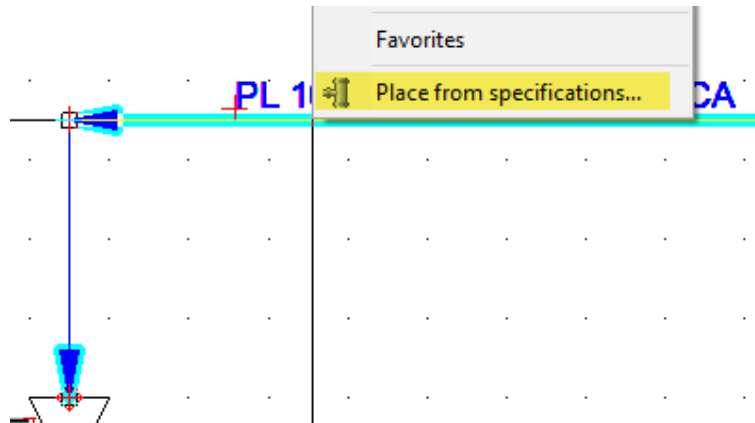

The existing functions are already extremely helpful and time-saving when creating new lines and line components and defining them for the first time.

Improvements when changing pipe specification parameters on existing pipes

If, however, the diameter and/or pipe spec of an existing pipe was changed, these changes were transferred to the pipes/lines, but this had no effect on already placed components (from function **Place from specifications**).

These still contained the old pipe spec definitions and a user was responsible for ensuring that these were adapted to the new pipe spec definitions.

In order to make this task much more comfortable and easier for the user, we have developed a new automation called **P&ID PipeSpec Component check**.

This automation is active by default from P&ID 2020 but can be switched off if required in the **Settings > Special settings**.



If a user now changes the diameter and/or pipe spec of an existing pipe via the function **Get specifications from Smapp3D Piping**, the new **P&ID PipeSpec Component check** is carried out automatically after confirming the changes (with **Ok** in Line article data window).

All components connected to the modified lines are checked for their belonging to the new diameter and/or the new pipe spec.

A short text information is displayed at each checked symbol.

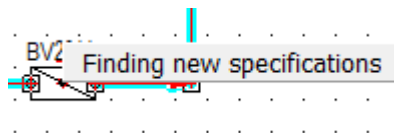

If the check is completed and the **placed components are not available in the new definition**, they are listed in the **P&ID Component check** dialog and **marked red**.

If the new pipe spec/diameter definition **does not contain any defined components**, **no result dialog** of the P&ID Component check is displayed, since there are no definitions for the next step.

Each line corresponds to an existing component where there is currently a misassignment of the contained information to the new pipe specification/diameter definition.

If a red line is selected, the **Update** button becomes active.

After clicking on **Update**, the database dialog with the filtered component content for the new pipe spec/diameter definition opens.

A user must select a new suitable component/article information from it and confirm with **Ok**.

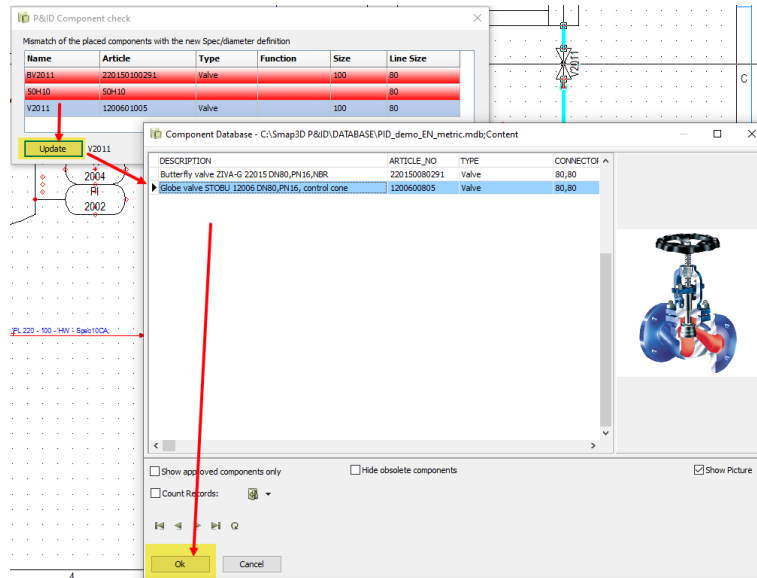

In the **P&ID Component check** dialog, the updated component/line is displayed in green.

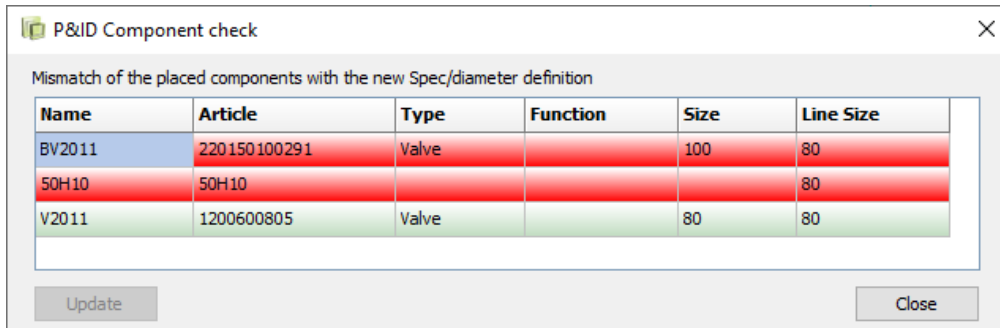

This process should be repeated for all components displayed in red if this is possible with the contents of the new pipe spec/diameter definition.

By clicking on **Close**, the automatic replacement of the existing components in the diagram is carried out for all rows displayed in green.

The enhancements of the **Replace Symbol** function are automatically applied.

If necessary, either only the article information is exchanged, or the complete symbol with article information is exchanged.

The requirements for this are taken from the pipe specification used and the active P&ID database.

No use of semicolon for pipe spec name anymore

Up to now, when using the function **Get specifications from Smap3D Piping** and automatically transferring the name of the pipe spec to the dialog **Line article data**, a semicolon ";" was always set/written at the end of the entry.

This is now changed so that no semicolon is written at the end of this value for new line definitions by default.

New dynamic connection line at PCE symbols

Until now, the connection line in **PCE symbols** was always static and exactly as long how it was drawn when the symbol was created.

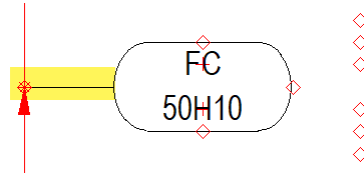

However, this static behavior of the connection line was not sufficient in all use cases to obtain the desired drawing result.

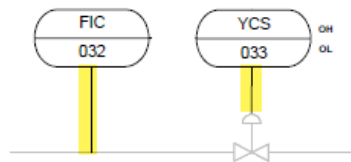

To make work easier for users, we have developed a dynamic connection line for PCE symbols.

Requirements for the correct functioning of the dynamic connection line

- A PCE symbol must be created with version **P&ID 2020** using the **symbol menu dialog (F8)** and the functions **New symbol** contained therein or edited and saved using **Edit symbol**.
- The symbol type **PCE** must be assigned to the PCE symbol with version **P&ID 2020** in the **symbol menu dialog (F8)** and the functions it contains.
If a correct PCE symbol is used, the symbol type is fixed in the diagram and cannot be changed there.
- The **connection point** at the end of the drawn connection line (with which the symbol is connected to a line) must have the name **1**.
- The drawn connection line must begin at this **connection point 1** and end at the symbol geometry.
- The dynamic connection line only functions if connection point 1 is connected to a line.
If this is not the case, the connection line continues to react statically as before.

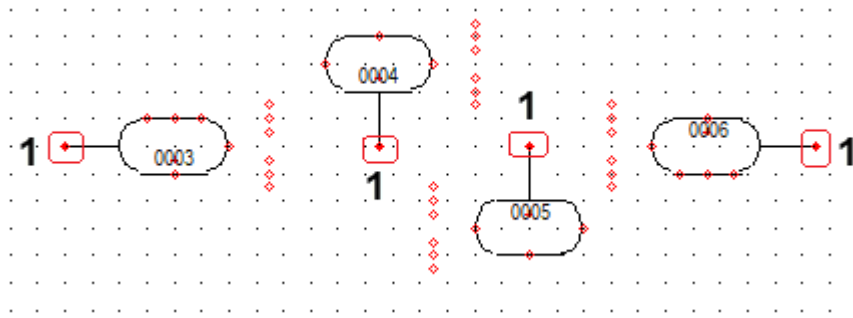

If all prerequisites are fulfilled, a connected PCE symbol can be moved in a diagram and the respective connection line dynamically adapts to the corresponding distance to the line.

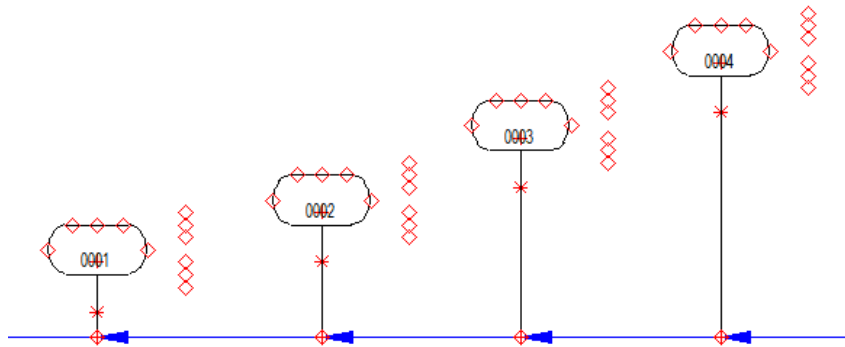

New functions for coloring P&ID objects

Previously, the color of the symbol geometry for P&ID symbols on diagram pages could only be changed from the color defined in the symbol library by using the function **Activate follow connected on symbols**.

The color of a connected line had to be changed in order to display the connected symbol in this color.

The function **Activate follow connected on symbols** is of course still available and can be used as before if required.

In order to simplify the individual coloring of P&ID symbols and lines for the user, new functions have been added to the corresponding context menus.

Prerequisites for symbols

For the functions described below for symbols to work correctly, a prerequisite must be fulfilled, as with the previous function (see above).

For all geometries contained in a symbol (lines, circles, and arcs), the **Follow connected**



function must be activated.

If this is not the case, the corresponding geometry will not change color for any of the functions (neither old nor new).

Individual coloring of lines, symbols, and areas/object groups

Lines

The coloring of **selected lines** can of course still be done using the original way, [changing of object properties](#) via the toolbar.

It might be faster and easier to use the new context menu function **Select color for line(s)**.

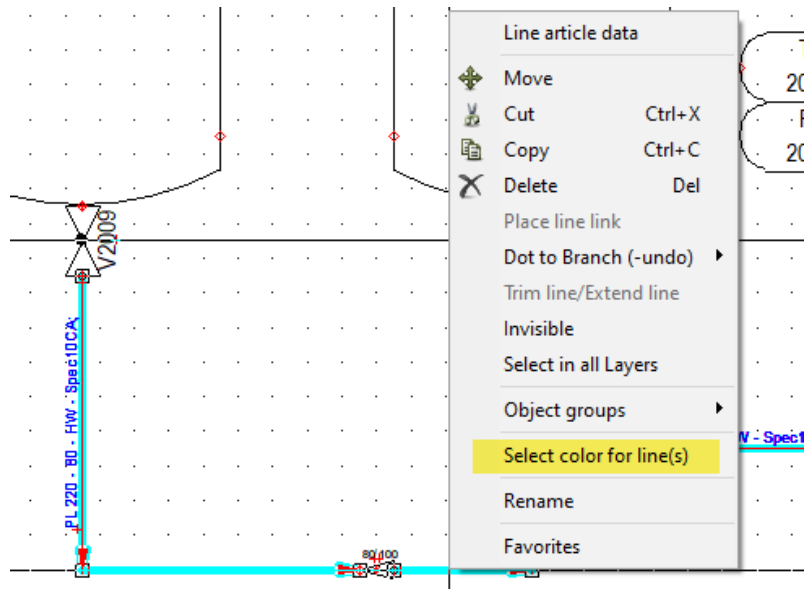

Click on it to open the dialog **Color**.

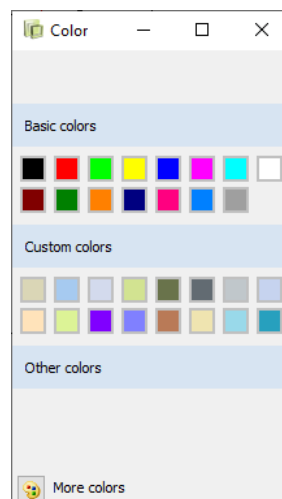

After clicking on the desired color, this dialog is closed, and the marked lines are automatically colored.

Visible line texts are not considered with this function. The text color can still be changed using the text attributes.

Symbols

You can use the context menu function **Select color for symbol(s)** to color **selected symbols** individually.

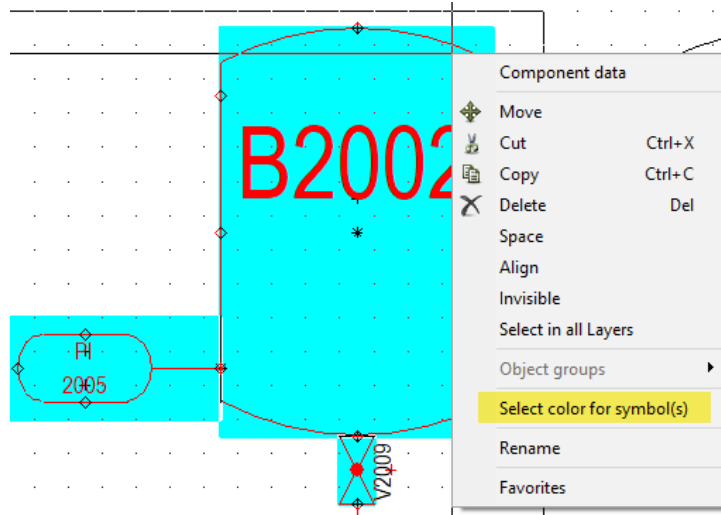

Click on it to open the **Color** dialog.

After clicking on the desired color, the dialog is closed and the selected symbols and their contained geometry (lines, circles, and arcs) are automatically colored if the [Prerequisite](#) is fulfilled.

Visible symbol texts are not considered with this function. The text color can still be changed using the text attributes.

Areas

The cross-object coloring of **selected areas (lines and symbols together)** is now also possible. The **Select color for area** context menu function is available for selected areas.

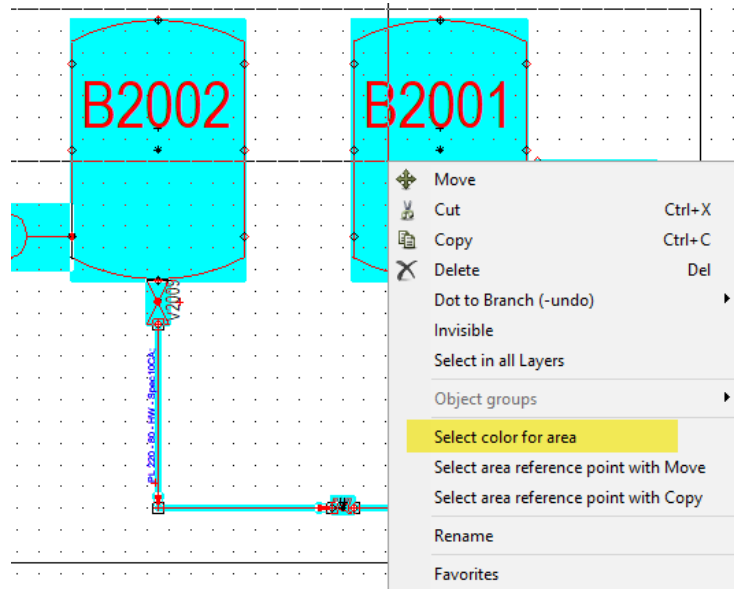

Click on it to open the **Color** dialog.

After clicking on the desired color, the dialog is closed and the selected objects (lines and symbols) are automatically colored.

For the symbol geometry marked in the area, the already mentioned [Prerequisite](#) applies.

Individual coloring of manually created object groups or placed sub-drawings

Since some versions, it is possible in P&ID to make an object group from individually selected objects on diagram pages.

Object groups are intended to simplify the subsequent selection of logically related individual objects on a diagram page for further operations.

The contents of prepared sub-drawings, which are inserted on a diagram sheet, also automatically have the definition of an object group after they have been placed.

In order to color all these logically related objects in a simple way, without first selecting all of them (as with function area), a separate function has been developed for this purpose.

If only one object of an object group is selected, the function **Select color for object group: "Name of object group" is available in the context menu **Object groups**.**

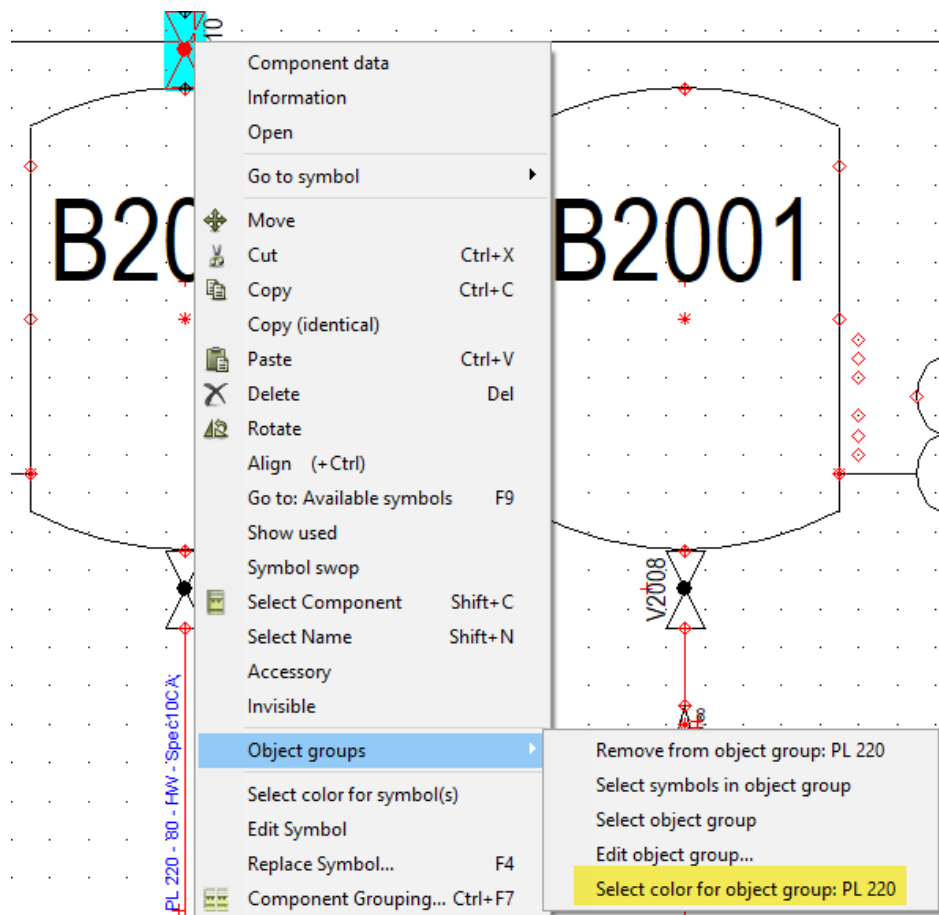

Click on it to open the **Color** dialog.

After clicking on the desired color, the dialog is closed and all objects belonging to the object group (all are already selected) are automatically colored.

Of course, the above-mentioned [Prerequisite](#) also applies to the symbols/symbol geometries contained in this object group.

Filter function in Object Lister

A new filter function has been added to the column headers of all available tabs and columns in the Object Lister.

Like the filter in Microsoft Excel, the new function allows you to filter and restrict the display of table contents for each tab.

A filter can be set for each column and several filters (for different columns) can be set simultaneously.

For active filters, the **Print** and **Save as file** functions use only the contents currently displayed in the object list.

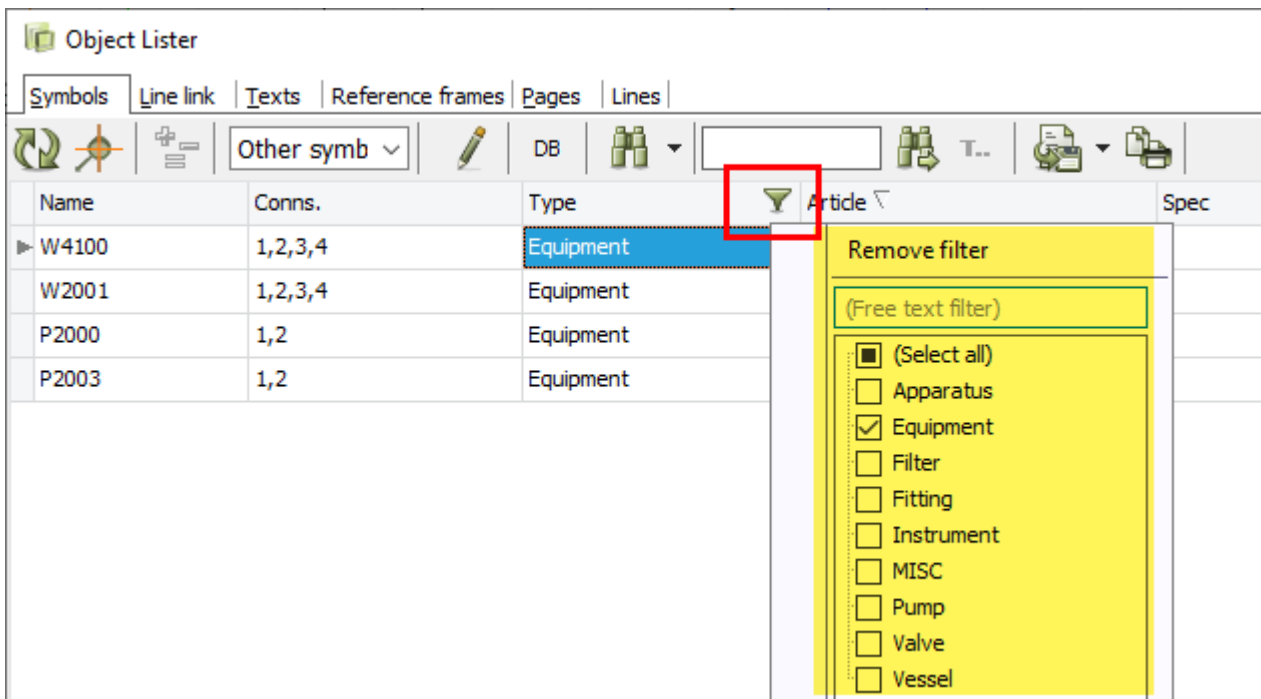

Formula editor for symbol data fields

The new technology introduced with P&ID 2019 behind the Formula editor for line data fields has been extended and made available for symbol data fields.

In the menu **Settings > Text/Symbol defaults**, the **Function for data field** button is available for existing **Symbol data fields**.

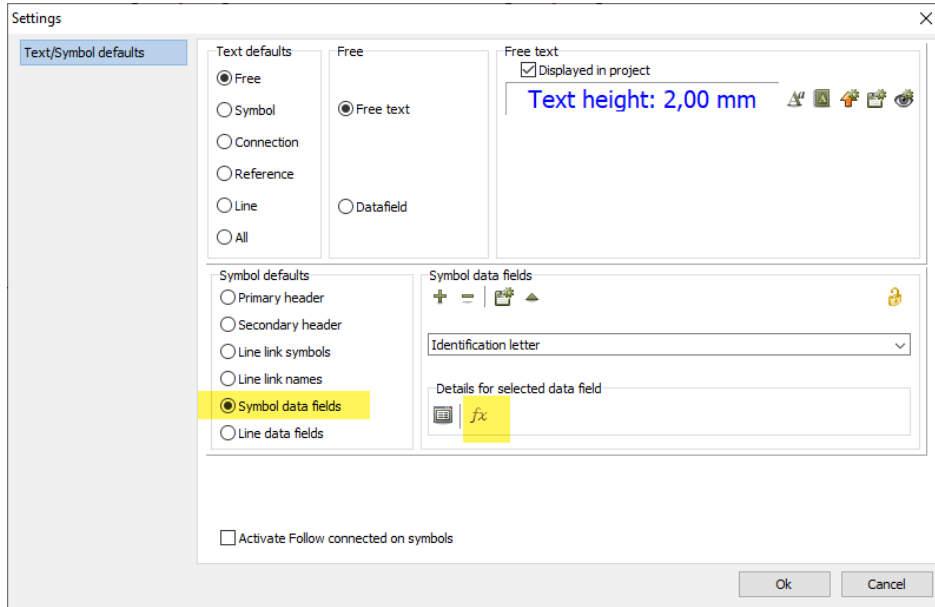

After selecting the desired symbol data field and clicking this button, the **Formula editor for data fields** dialog opens.

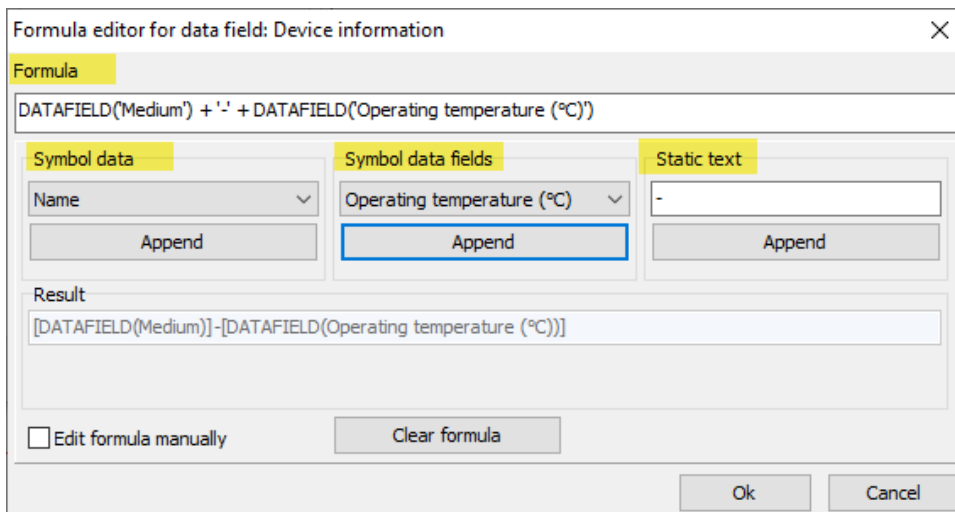

With the same function as for line data fields, but with different selection list contents, you can now also define the concatenation of values from individual data fields in one symbol data field.

New list type Connections List

In addition to the known list types **Component list** and **Parts list**, which can be inserted as independent pages to a P&ID project, there is now a third type, the **Connections list**. Connections list could previously only be exported as a **Connections list file**. Use as internal pages were not possible up to now.

In contrast to the previous internal list sheets (component and parts lists), the focus of the evaluation in a **Connections list** is not on the symbols/components, but on the **lines**.

And exactly for such evaluations, this list type should be used.

Line - Name	Line - TAG	From Component	To Component	Line - Type
PL 90	PL 90 - 65 - WW - Spec10CA	V1102:2	K1001:8	40
PL 70	PL 70 - 40 - CO - Spec10CA	V2000:2	RV2000:1	50
PL 51	PL 51 - 50 - CW - Spec10CA	V2000:3	2003:2	

Default templates

With the installation of P&ID 2020, we provide prepared example templates for such connections list with corresponding list symbols.

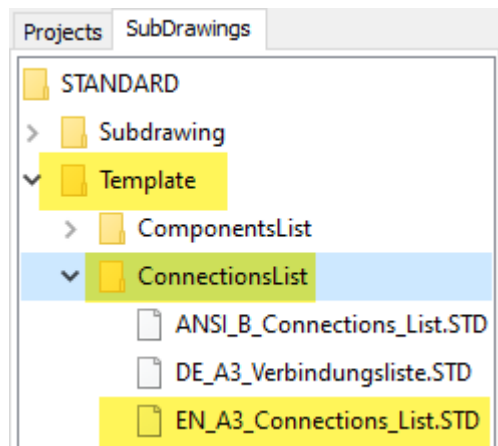

Of course, customers can also create their own templates and symbols for connections lists. Please make sure that the page function **Connections list** is set for a user-specific template page.

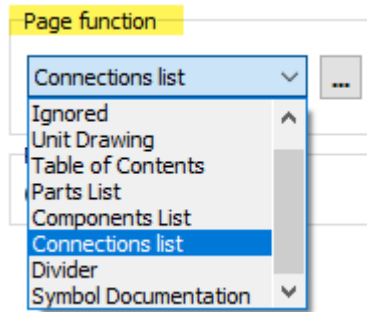

After inserting a user-specific template page into a project, it must be displayed as a **NET** page type.

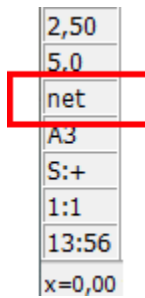

Excel template for list exports usable

For all types of list exports using the "...List File" functions, a template can now be set and used when exporting to Microsoft Excel® file format.

After calling the desired function "...List File" and selecting the file format on **Microsoft Excel®**, the option **Use template** is activated in section **Template**.

Via the button **Browse ...** the path to the desired template can be set.
 Permitted file extensions are ***.XLS** and ***.XLSX**.

In the field **Top left cell**, the cell name must be entered from which the Smap3D P&ID list in the selected template is to be filled automatically.

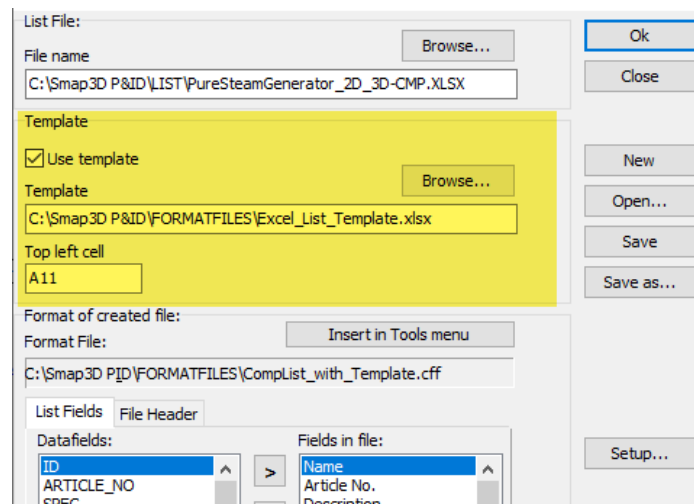

The result can look like this.

User name	?			
Date	05.12.2019			
Time	14:11:18			
Company name	?			
Project No.	643/12345			
Project name	Pure steam generator PSM 500			
Customer	CAD Partner GmbH			
Address	Am Marktplatz 7			
ZIP code	93152			
City				
Phone No.	09404 9639 21			
Telefax				
Title	Pure steam generator PSM 500			
Name	Article No.	Description	Medium	Operating te
PL 50	091269		CW	
PL 51	091269		CW	
PL 60	333355		HW	
PL 61	046666		HS	
PL 70	611111		CO	

New display grouping for Symbol data fields

For the intensive work with many symbol data fields, the new function **Symboldatafield groups** for the display grouping of symbol data fields was developed. Symbol data field groups should help a user to quickly and directly access the data fields required in respective situations.

Definition of Symbol data field groups

Symbol data field groups are defined using the **Edit symbol data fields** tool (in **Tools** menu).

In the **Edit contents** tab, the button  is located at the left bottom and a click on it opens the corresponding menu.

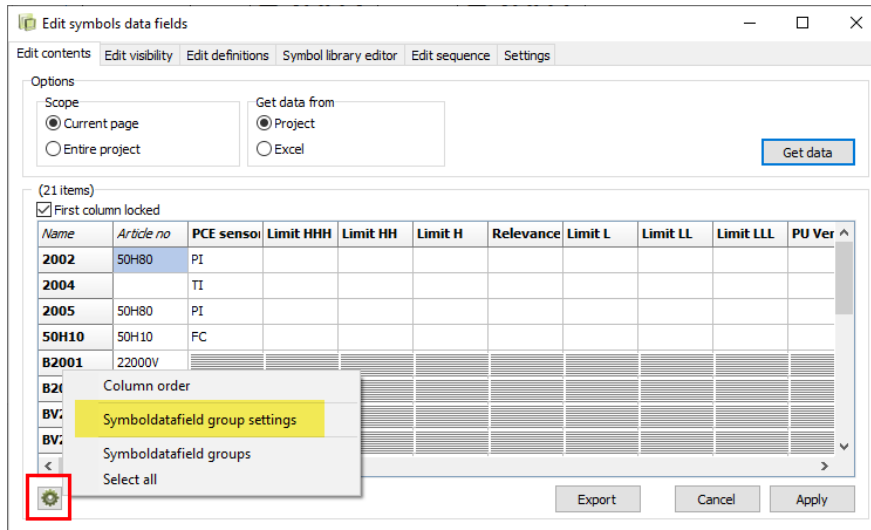

After clicking on **Symboldatafield group settings**, the dialog opens.

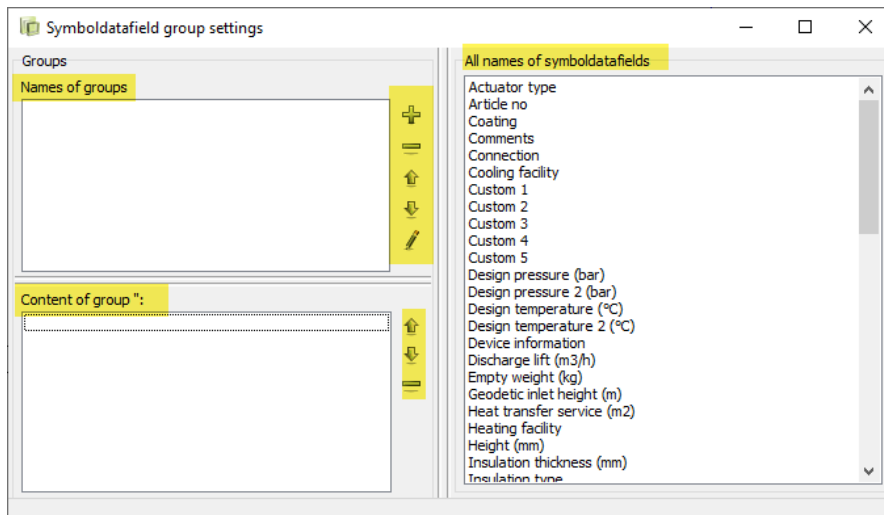

The right column **All names of symboldatafields** displays all symbol data fields available in the active project.

Click on the button  to create a new group.

After entering the desired group name and clicking **OK**, this group is created and displayed in the upper left area.

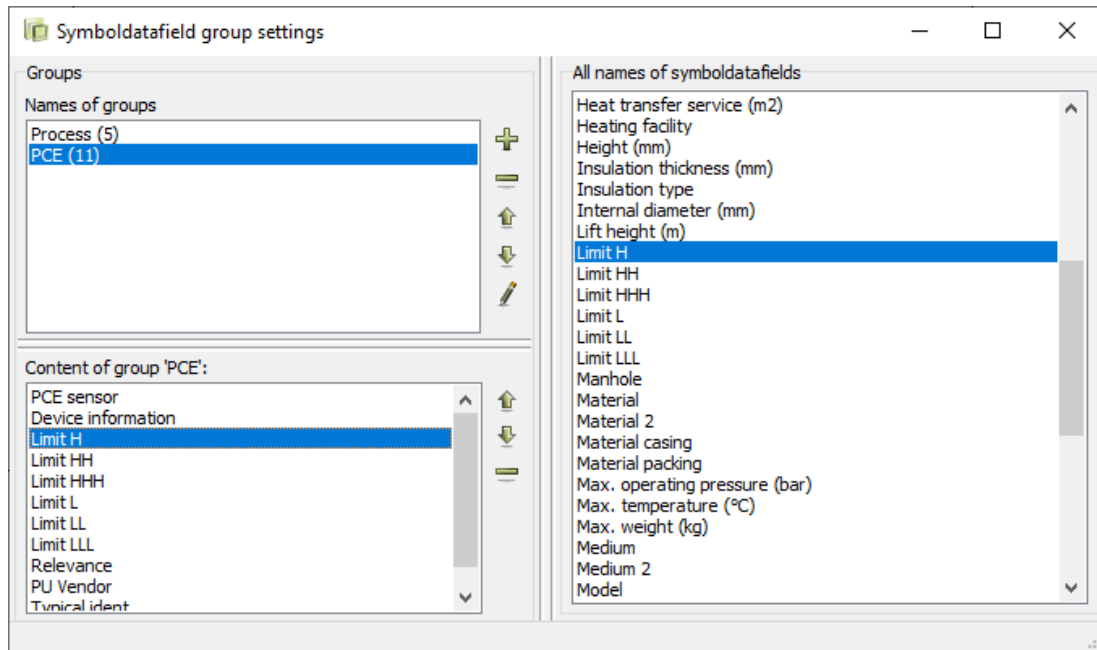

Using **is Drop** you can move all symbol data fields for the selected group from the right column **All names of symboldatafields** to the area **Content of group "xxx"**.

This process can be repeated for any number of groups with content.

The number of symbol data fields added to the group is displayed in parenthesis next to the **name of the group**.

After clicking on a group name, the contained symbol data fields are displayed in the area **Content of group "xxx"**.

With the respective buttons to the right of the name of the group and content of group sections, the existing definitions can be adapted at any time.

By closing the dialog (**x** top right), the settings are saved and applied.

Applying symbol data field groups in the Edit symbol data fields tool

If symbol data field groups are defined, these are displayed directly in the **Edit symbols data fields**, **Edit contents** tab.

The symbol data fields combined with symbol data field groups are displayed with colored column headings.

The name of the symbol data field group is also displayed in this column header.

All columns that do not belong to a symbol data field group are displayed in grey and therefore belong to the group "not grouped".

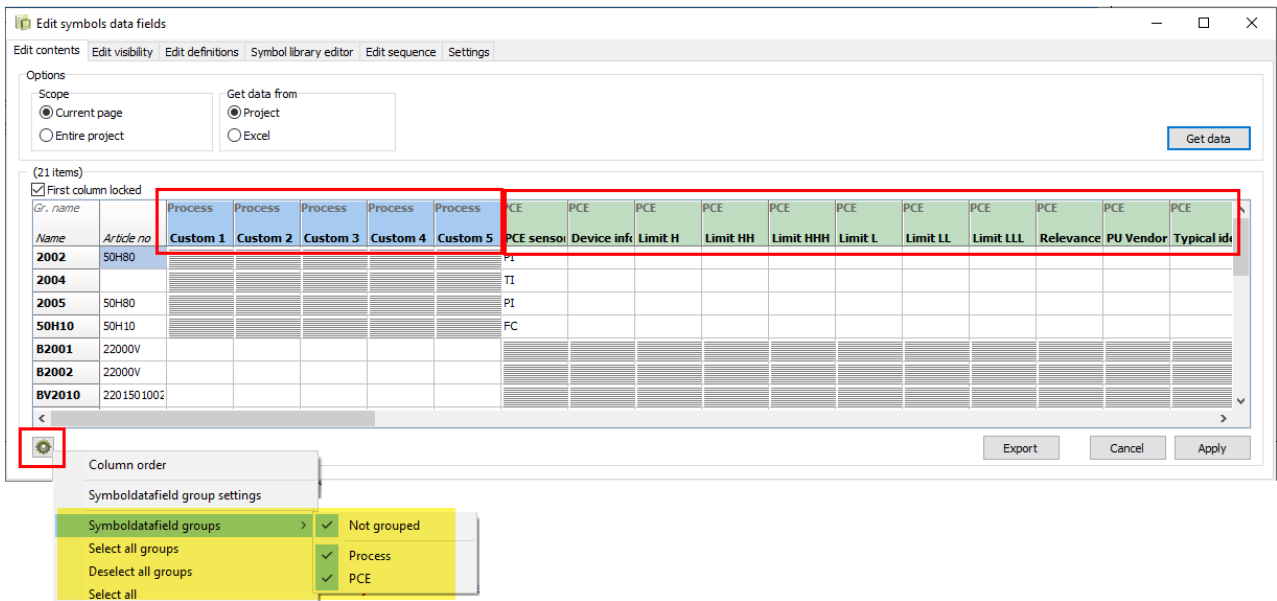



If symbol data field groups are defined, they can be shown or hidden as required.

In the menu of the button  corresponding functions are available, with which a user can control the display of symbol data field groups according to his own wishes.

Applying symbol data field groups in the Component data dialog

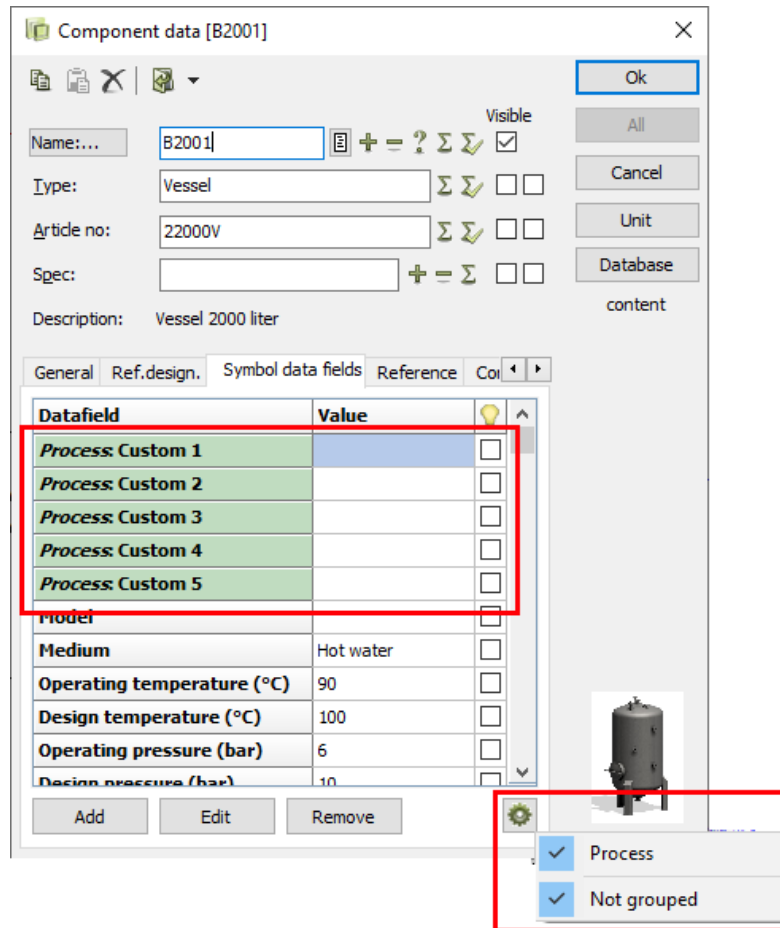
If symbol data field groups are defined as described above, they are also available in the **Component data** dialog and can be used there.



All symbol data fields of a symbol that belong to symbol data field groups are displayed in color. In these cases, the button  is displayed at the bottom right. Not displayed if no symbol data field groups are defined.

Clicking, it lists the names of the existing symbol data field groups. By setting or removing the checkmark, the display (**show or hide**) of the associated symbol data fields can be controlled.

New symbol data fields "Description"

The new symbol data field **Description**, for the use in symbols and lists, has been added.

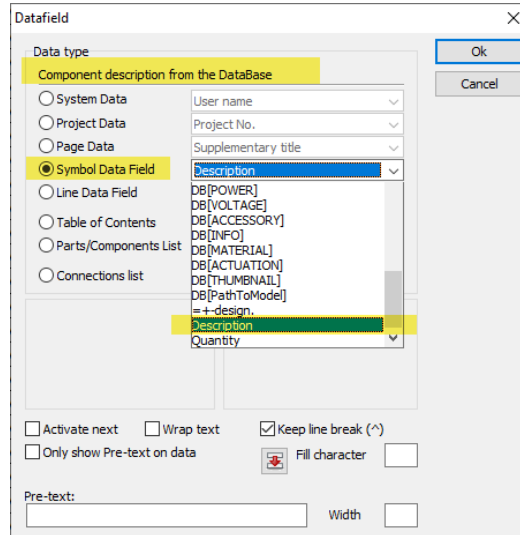

If this symbol data field **Description** is defined and used in a symbol, a user can manually enter a value for it if there is no article assignment from the database for this symbol. Since the standard data field with the same name is reserved exclusively for the value from the database, this was previously not possible.

The entered value then appears automatically in a component list (Description column), if the symbol does not contain an item assignment from the database. This new option is intended to support users who want to create lists of manually entered items at an early stage (e.g. during PFD creation and before final item assignment), to evaluate the basic contents.

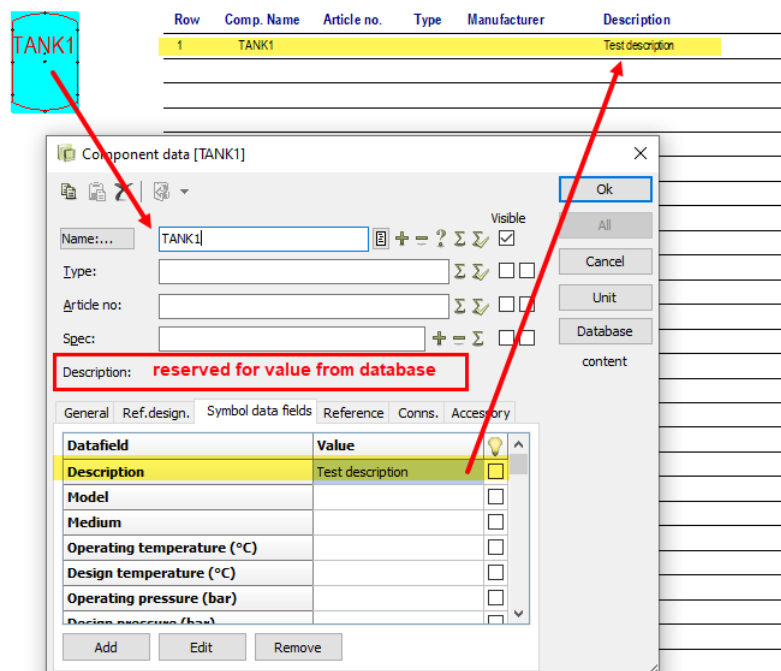

If an article from the database is then assigned to a symbol, this symbol data field is filled with the value from the article database in the same way as the standard data field, and this value is then automatically used in the list evaluations.



Row	Comp. Name	Article no.	Type	Manufacturer	Description
1	TANK1	25006V	Vessel	MaBe GmbH	Vessel 5000 liter

Component data [TANK1]

Name: TANK1

Type: Vessel

Article no: 25006V

Spec:

Description: Vessel 5000 liter

Visible:

Buttons: Ok, All, Cancel, Unit, Database, content

General | Ref.design. | **Symbol data fields** | Reference | Conns. | Accessory

Datafield	Value	Lightbulb icon
Description	Vessel 5000 liter	<input checked="" type="checkbox"/>
Model		<input type="checkbox"/>
Medium		<input type="checkbox"/>
Operating temperature (°C)		<input type="checkbox"/>
Design temperature (°C)		<input type="checkbox"/>
Operating pressure (bar)		<input type="checkbox"/>
Design pressure (bar)		<input type="checkbox"/>

Buttons: Add, Edit, Remove

New data field "Thumbnails field" for data sheets and lists

The **Thumbnails field** data field can now be used in symbols for data sheets or components lists.

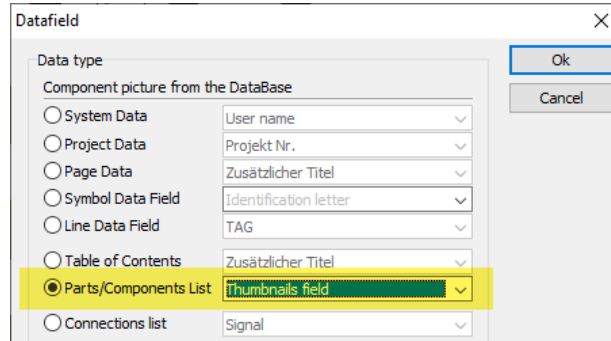

If such a data sheet is used in a project, an existing image of the component is displayed at the position of the **Thumbnails field**.

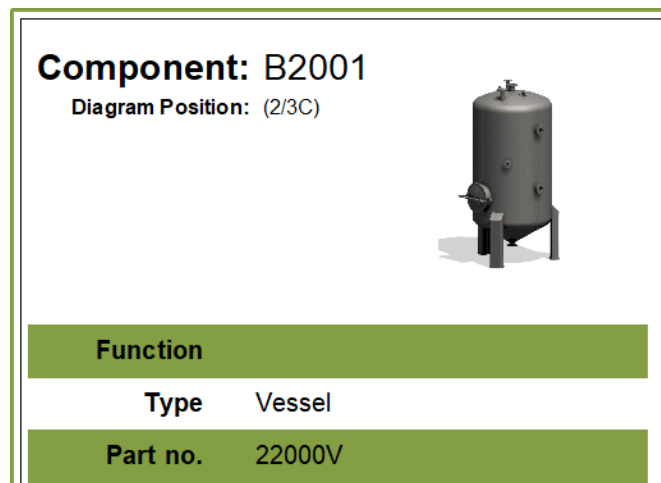

Such an image must be prepared and available in the article data record of a component in the database.

The same settings must be made for displaying an image in the database view or in the component data view.

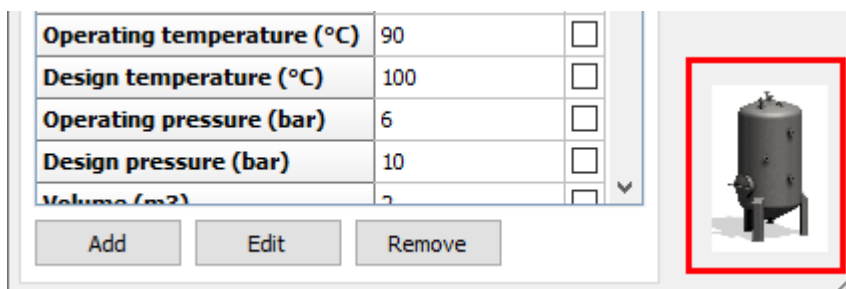

New function Assign for "Read components list"

For many versions, the **Read components list** function has been available in the **Lists** menu. This function can be used as a kind of "To-Do list" for creating P&ID diagrams. An Excel table can be loaded from which new diagram contents (symbols with article information) can be inserted.

Name	Article No.	DESCRIPTION	Medium	Operating temperatur...	Design temperature (°C)	Operating pressure (bar)
P2002	96539052	...	Hot water	95	100	5
B2001	22000V	...	Hot water	90	100	6
B2002	22000V	...	Hot water	90	100	6
W2001	PK400-35	Tube type heat exchanger with fixed tube s...	Cold water	40	50	6
50H10	50H10	Flowmeter Proline Promag 50H, DN100, PN16				
2002	50H80	Flowmeter Proline Promag 50H, DN80, PN16				
2004						

New function

As an enhancement to previous options, we have added the **Assign** function. If symbols have already been placed in a diagram (without article information), a user can use **Assign** function to transfer the information from an Excel table, line by line to existing symbols.

Name	Article No.	DESCRIPTION	Medium
RV2000	122001	Check valve, general	Medium
P2003		Rotating pump with electric motor	Cold water
P2002		30-250/247 A-F2-A-E-BAQE	Hot water
P2002	
P2000	114001	Pump, general	Cold water
K1001	102005	Column with specified number of trays	
I1002	0708	Sight glass with humidity indicator	
I1001	125012	Steam trap	Condensate

Transfer also symbol data fields

In addition to the standard article information from the P&ID database (via article number), existing symbol data fields, when the correct configuration is made, i.e. when the correct configuration file for components lists *.CFF is assigned when the Excel table is loaded.

The screenshot shows the 'Components List - PureSteamGenerator_2D_3D-CMP.XLSX' table and the 'Component data [B2001]' dialog box.

Name	Article No.	DESCRIPTION	Medium	O..	D...	O...	D...	M...
B2001	22000V	Vessel 2000 liter	Hot water	90	100	6	10	1
B2002	22000V	Vessel 2000 liter	Hot water	90	100	6	10	1
BV2010	220150100291	Butterfly valve ZIVA-G 22015 DN100,PN16,NBR						
BV2011	220150100291	Butterfly valve ZIVA-G 22015 DN100,PN16,NBR						
F1000	105001	Filter, general	Heating steam					

Datafield	Value	Visible
Model		<input type="checkbox"/>
Medium	Hot water	<input type="checkbox"/>
Operating temperature (°C)	90	<input type="checkbox"/>
Design temperature (°C)	100	<input type="checkbox"/>
Operating pressure (bar)	6	<input type="checkbox"/>
Design pressure (bar)	10	<input type="checkbox"/>

New module "Create ZIP package of linked files"

The Tools menu contains the new module **Create ZIP of linked files**.

if this module is executed, a database query for linked files is carried out for all symbols contained on diagram pages in the active project.

The database field from which the link is used is defined in the database settings.

If linked files exist, they are "copied together" and stored in a ZIP file in the same folder as the active PRO file.

Users can now easily and conveniently provide the P&ID diagrams together with these additional files to their customers.

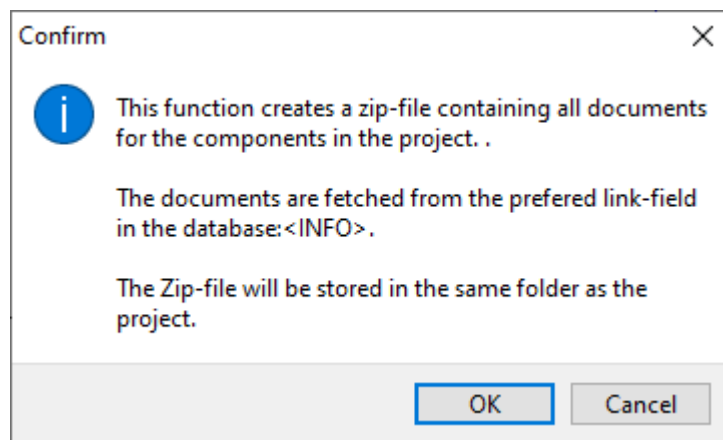

New backlink from Unit pages to symbol on diagram pages

If a user works with unit pages in a project, you can always jump from the placeholder symbol to the linked unit page by clicking **Open**.

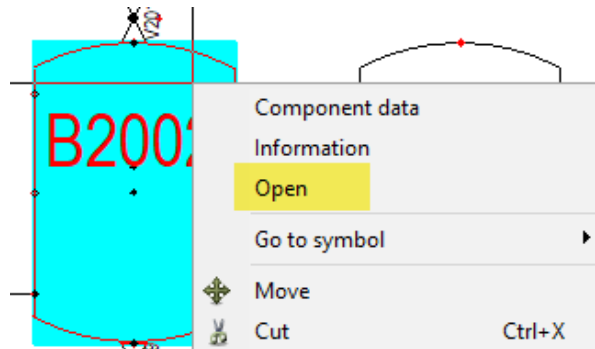

With P&ID 2020 we have now added a **backlink from a unit page** to the **linked symbol**. For this, you must place the new data field **Unit name list** once in the **symbol of the unit parts list** (not several times to the lines).

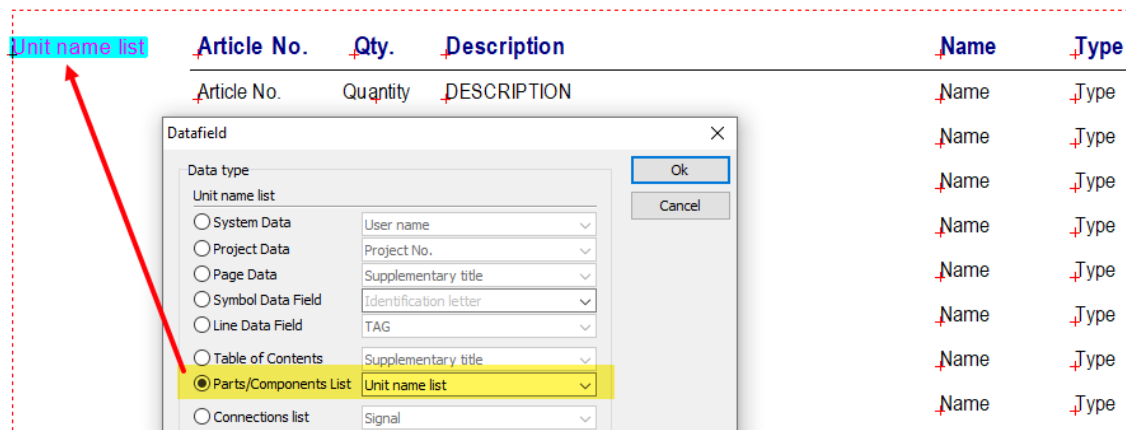

If this unit page is linked to a placeholder symbol in a project, the names of the placeholder symbols are displayed there.

By clicking on one of the displayed names, the backlink to the corresponding page and the symbol is executed.

B2002, K1001	Article No.	Qty.	Description
	25006V	1	Vessel 5000 liter
	1207	1	Bag filter, cartridge filter for gases
	121007	1	Ball valve
	1200600805	2	Globe valve STOBU 12006 DN80, PN16,
	0201	1	Valve, general at normal operation

Configurable display in Accessory tab

In response to many customer requests, the display in the Accessory tab has now been made configurable.

This means that a user can set additional columns for displaying information from the non-graphic accessory from the database in this tab.

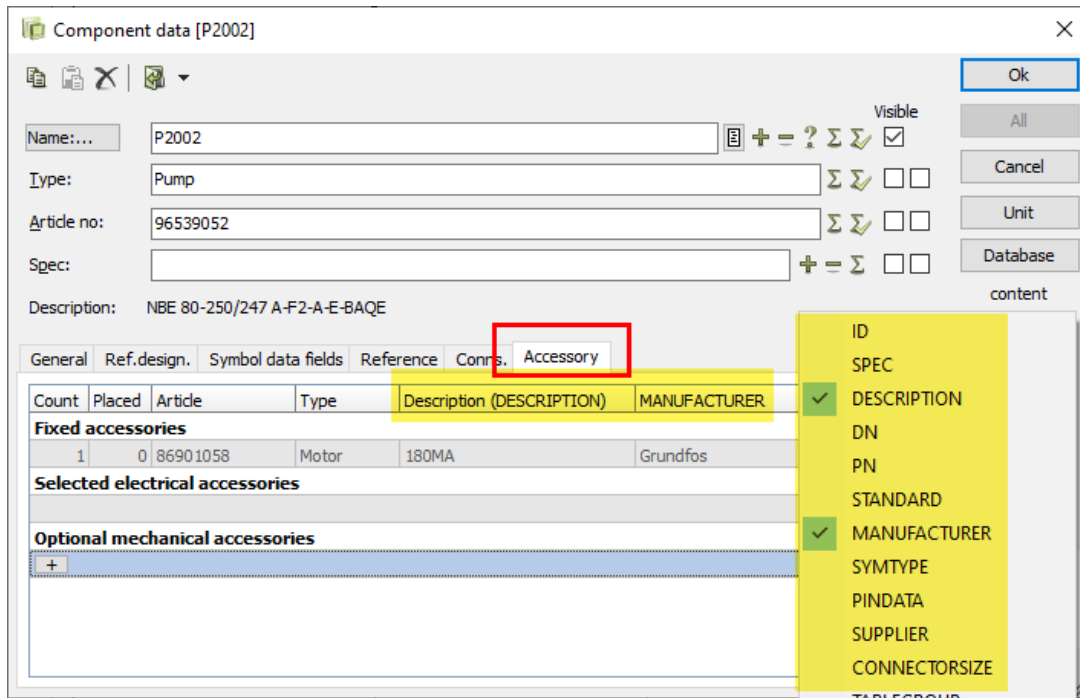

Changes made here are also displayed in the diagram in the quick info of a symbol.

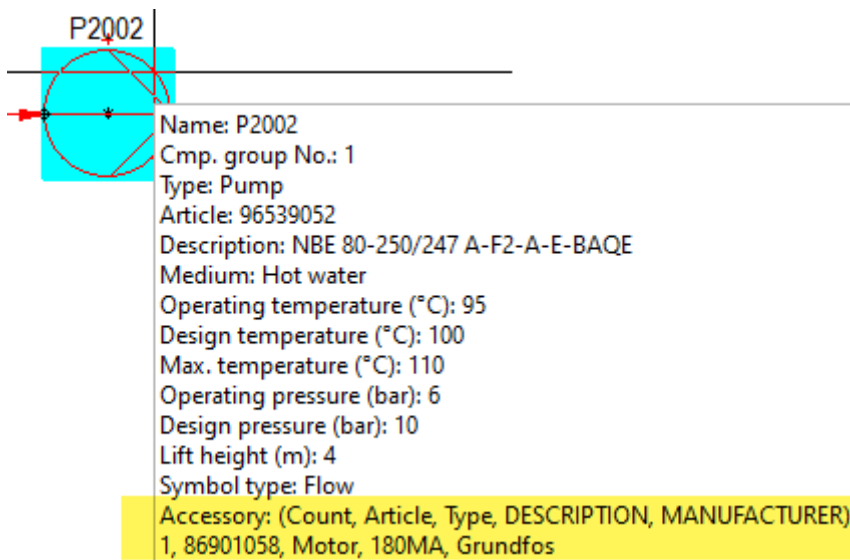

Enhanced command line parameters for PDF export

The necessary command line parameters have been extended for all customers who need to automate the creation of PDF exports of PRO files in interaction with other systems (e.g. with PDM or ERP).

Previously, existing PDF export configurations (*.pdfset) could not be used via command lines (*.CMD files), but only by the user via the P&ID software interface.

With P&ID 2020 this is fixed and the *.pdfset files can also be used for automated exports.

The new parameters for use in command line files (*.CMD) are as follows:

FILESAVEAS .pdf <Mysettings.pdfset> MyProjectfile | @MyProjectListFile <MyOutputPath>

Example without pdfset file:

FILESAVEAS .PDF c:\Myprojects\Myproject.pro

Example with pdfset file in folder FORMATFILES:

FILESAVEAS .PDF MySettings.pdfset c:\Myprojects\Myproject.pro

Example with pdfset file in any folder/path:

FILESAVEAS .PDF d:\myfolder\MySettings.pdfset c:\Myprojects\Myproject.pro

Message display when PRO file is write-protected

If PRO files are opened which are write-protected, the following message will be displayed permanently in the header of P&ID in addition to the message when opening the file.

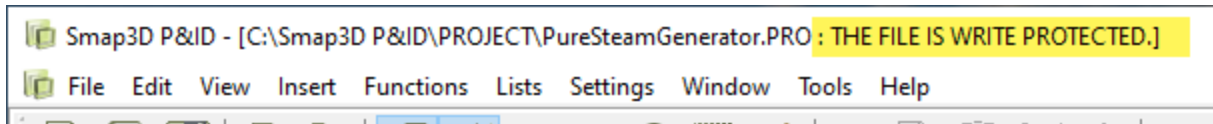

Symbol data fields from database write-protected

If symbol data fields are defined in symbols which are directly linked to the database (display always with **DB[xxxx]**), these are write-protected from P&ID 2020 and **cannot be given values by user input**.

Values for such symbol data fields are filled exclusively by the database as soon as a symbol receives an article assignment (article number).

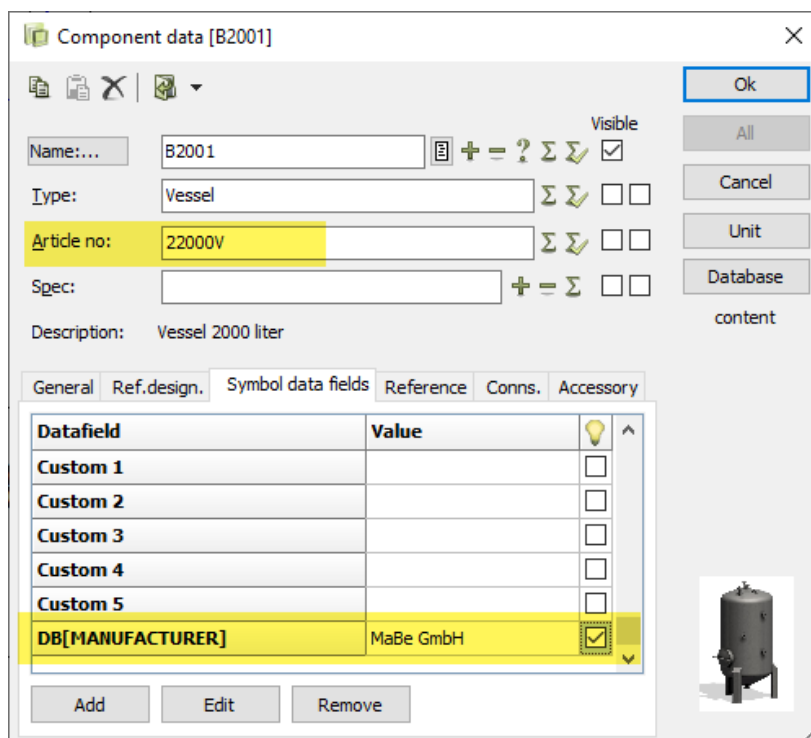

Line priority now also in Quick Info window of a line

Since P&ID 2019 there are settings for line priority.
 Now the corresponding info is also displayed in the quick info window of a line.

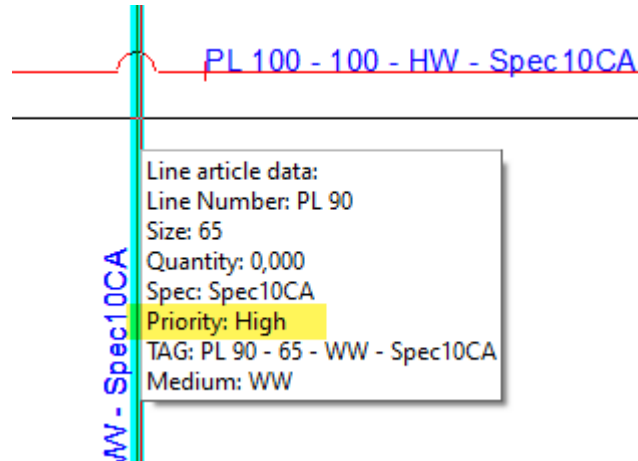

New setting for individual text width at Text properties

For all types of P&ID internal texts, individual text widths can now also be set for True-Type fonts.
 This was previously only possible for the integrated standard PCschematic font.

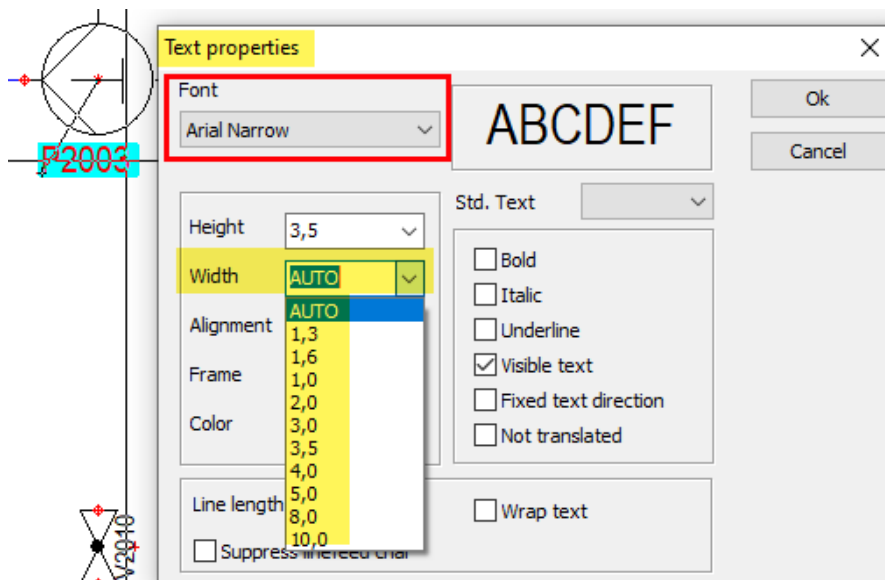

New option to switch off arrows on leader lines

Since P&ID 2017 there is the possibility to use Leader lines for text. The settings for this have been enhanced to switch of the arrow on the leader line for certain use cases.

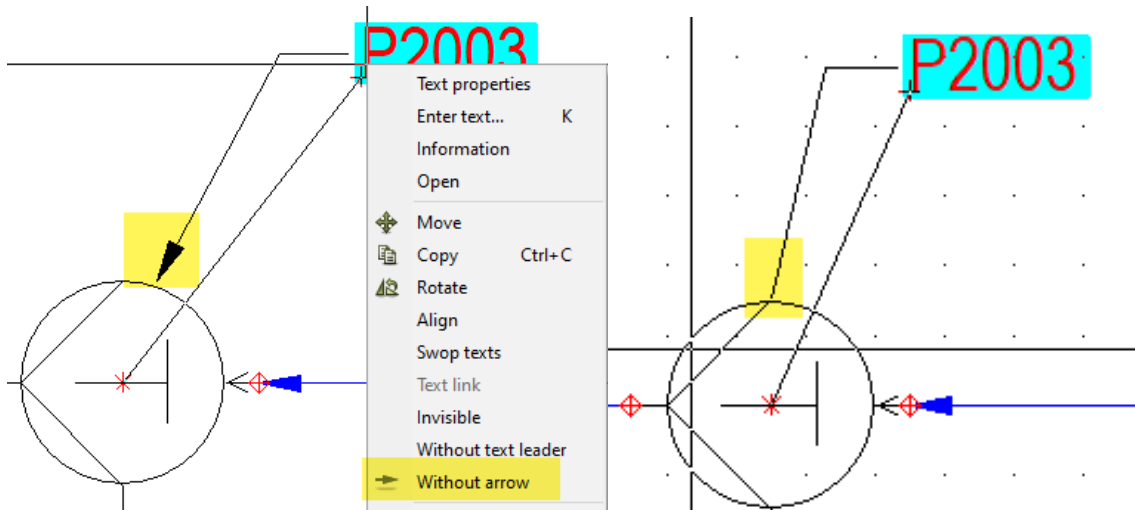

New French language for user interface

With P&ID 2020, the software can also be operated with the French language for the user interface. In the **Select language** setting, the entry **FR** stands for **French**.

Improved zoom and pan performance

Especially with large-format diagram pages with a lot of content (per page), the performance for zoom and pan in relation to the content of the page went down in previous versions. In order to correct and improve this, the algorithms behind the zoom and pan functions in P&ID 202 have been completely reworked.

During our internal tests with such large-format customer projects, we can see an enormous improvement.

Previously jerky zoom and pan behavior can now be performed smoothly.

other small enhancements/changes:

- In the **List settings**, tab **Replaces**, further user-specific fields can now be added (previously limited to 7 fields).
- The **Component menu/Components** window remains collapsed/hidden until the **Available symbols (F9)** function is used or activated for specific actions. Previously unfolded after every start of P&ID.

New in Component Wizard

New option to register directly in Part Finder database

Previously, the Component Wizard had only supported the **File System Provider** for later use in pipe specifications as the storage location for the prepared parts. Due to multiple customer requests, this has now been extended.

In the last step **Save component**, the option **Preselected Standard Parts Provider** is now available.

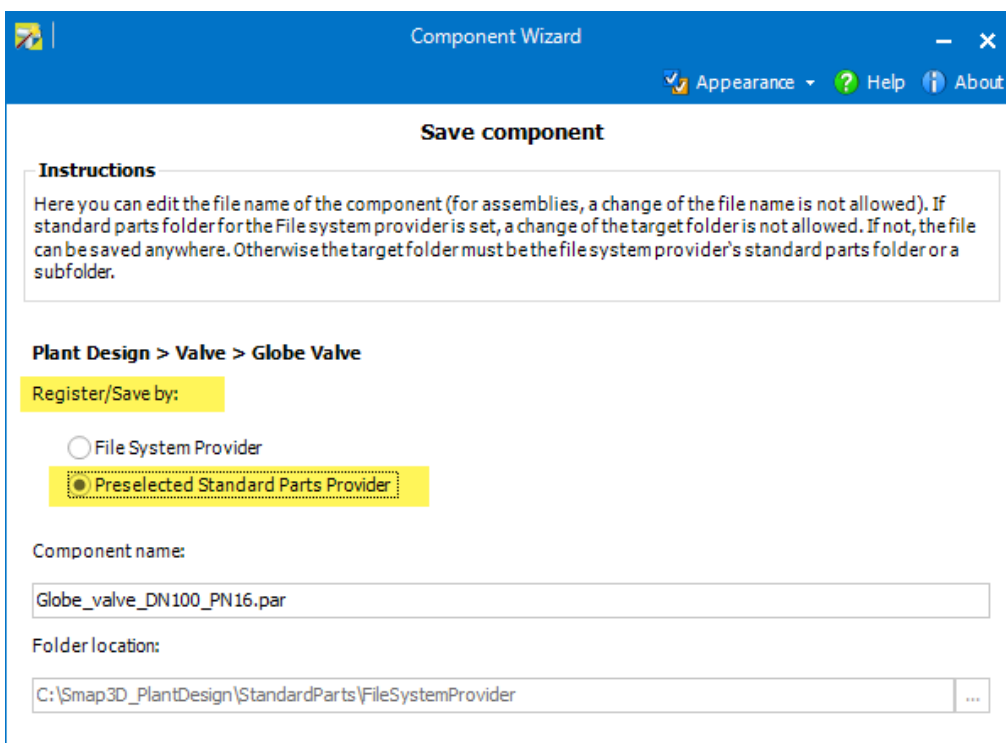

If this is activated, the **Standard parts provider** system is used, which is set in the Plant Design Administrator.



Since most of our Plant Design customers use the **Part Finder** (from Smapp3D Parts Management), the next steps are described accordingly.

After confirming the corresponding messages, the **Database administrator** is automatically started with the function **Add Part**.

The Part Finder storage location rules are automatically applied.

With this new option, the part prepared in the Component Wizard can now be registered directly in the Part Finder database.

Manual steps, as well as manual switching between the applications Component Wizard and Database Administrator, are no longer required.

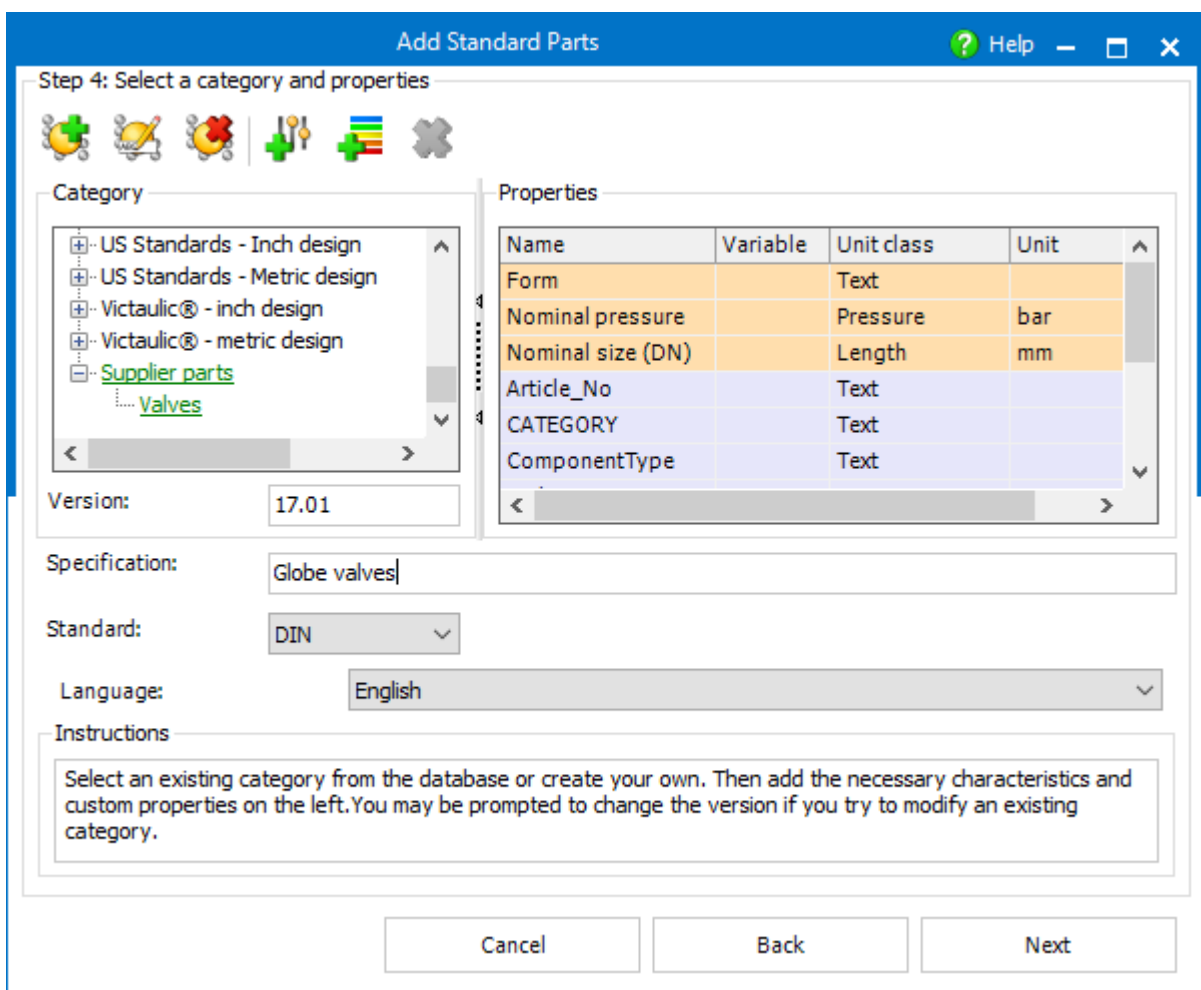

New in Smapi3D Parts Management

Parts Management Administrator and Plant Design Administrator loaded together in one dialog

Since most Smapi3D Plant Design customers use our Smapi3D Part Management as their 3D standard parts management system, version 2020 combines the two necessary administration programs in one dialog for the users.

When the **Plant Design Administrator** is started, the **Part Management Administrator (as a plug-in)** is automatically loaded into the Plant Design Administrator dialog.

Thus, a user has access to all relevant administration settings for the entire Smapi3D Plant Design solution in one dialog.

Changes in the respective program, but still must to be saved separately for each tab/program (Save button), since two different configuration files are still available and used in the configuration folder.

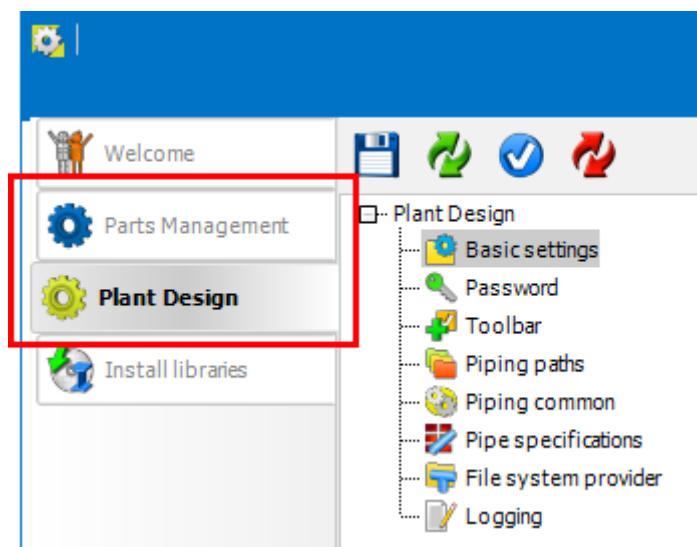

Database Administrator can be started directly from Part Finder

The Parts Management programs **Database Administrator** and **Part Finder** are clearly separated from their intended purpose.

The **Database Administrator is an administration tool** for the central creation and maintenance of the 3D standard parts database.

The **Part Finder is a user tool** to use the contents of the 3D standard parts database defined in the Database Administrator for various purposes.

In order to make the interaction of these individual programs and their use easier for the user, the Part Finder and the Database Administrator have been linked together.

The new button

The Part Finder contains the new **Manage DB** button for starting the Database administrator.

If the Database Administrator is secured by a password, this must be entered before the application window opens.

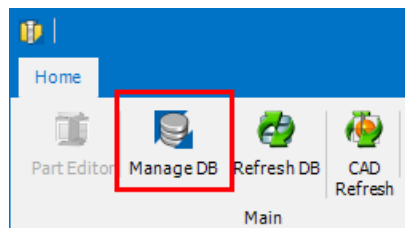

Working in Database Administrator

In the Database Administrator opened in this way, the desired work on the database and the database contents can be carried out as usual.

Automatic synchronization of Part Finder display

After the Database Administrator has been closed, the display in the Part Finder is automatically synchronized with the database.

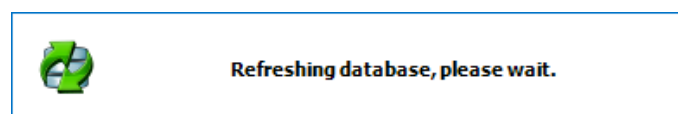

This ensures that all changes or extensions made in the Database Administrator are immediately available to the user in Part Finder. The user can then continue working with Part Finder as usual.

Parts Management updates physical properties during generation

In the previous version of Parts Management, as well as in all previous versions of Smapp3D PDM 9.6, only the geometries and features for the 3D model were created and saved when generating standard parts from supplied parent parts.

Any existing definitions for the material (from CAD material table/library) and the associated physical properties were never updated.

Previously, this had to be done additionally and subsequently to the already generated parts

In order to avoid this additional effort for users, all Parts Management applications can use and update the material definitions and physical properties stored in the parent parts when generating new variants.

Activate this option in the Parts Management Administrator

For this new function to be used by the Parts Management programs, it must be activated in the Parts Management Administrator.

In the sub-item **Properties**, the new option **Apply material to generated parts** must be activated and saved.

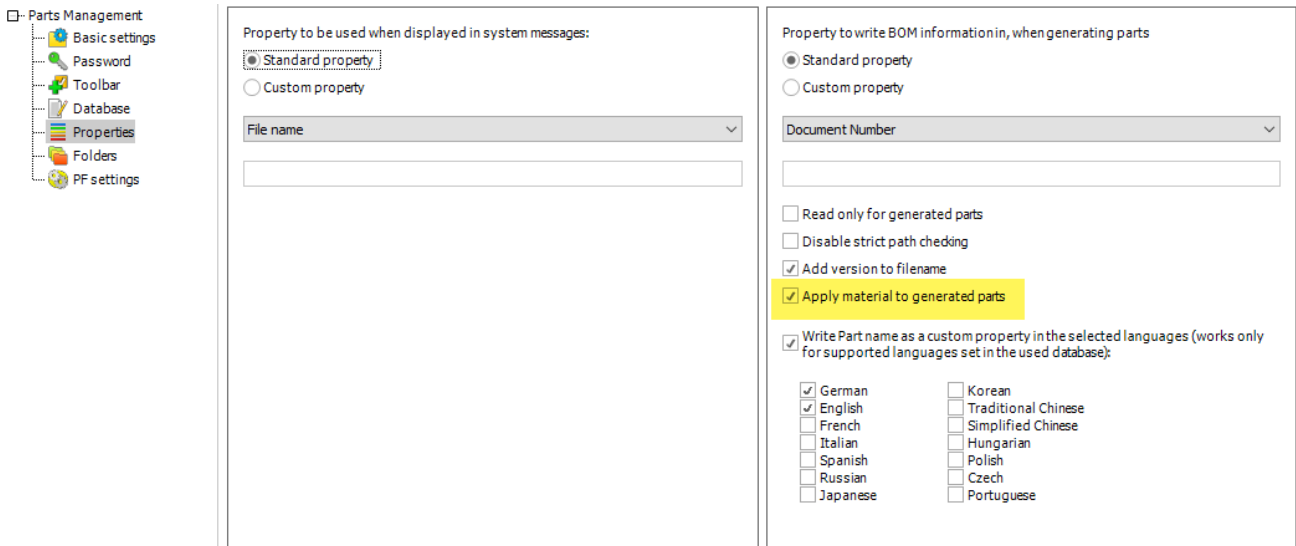

Necessary requirements

The prerequisites for a correct result in the generated parts are as follows (with active option):

- For the **original part / parent part** from which the new parts are generated, the selection characteristic **Material** exists in the database with a valid value (the material name from CAD material table/library),

or,

- in the **original part / parent part** from which the new parts are generated, a **Material** is already assigned with CAD functions.
- Accordingly, a correct value must be included in the custom CAD file property **Material**.
- In addition, the custom CAD file property **MaterialLib** must contain the name of the material library used as the value.
- The existing **material of the original part / parent part** must also be available in the CAD material table/library on the computer on which the part is generated.

Support for Microsoft SQL Server 2017 and Microsoft SQL Server 2019

The official support of Microsoft SQL Server 2017 and Microsoft SQL Server 2019 has now been added for all customers who have purchased the additional license for operating the Parts Management 3D standard parts database on a Microsoft SQL server.

This means that the Part Finder database can also be run on these Microsoft SQL server versions.

New in Smap3D Piping

New QuickPlace method Grooved Coupling

For the automated use of grooved connection systems with Smap3D Piping, we have developed and added the new QuickPlace method (placement automation) **Grooved coupling**.

This new automation is specifically designed for the placement of grooved couplings from manufacturer-specific connection systems such as Victaulic®, QUIKCOUP®, Richmond® and others.

Unlike the automation of the normal coupling, a **Grooved coupling** demand on an existing component requires the new **ET19** end-treatment.

By using the new **Grooved coupling** automatic placement in combination with the already existing automations (e.g. elbow 90, tee, etc.) in a pipe specification, users can quickly and fully automatically generate complex pipelines with such grooved components with Smap3D Piping.

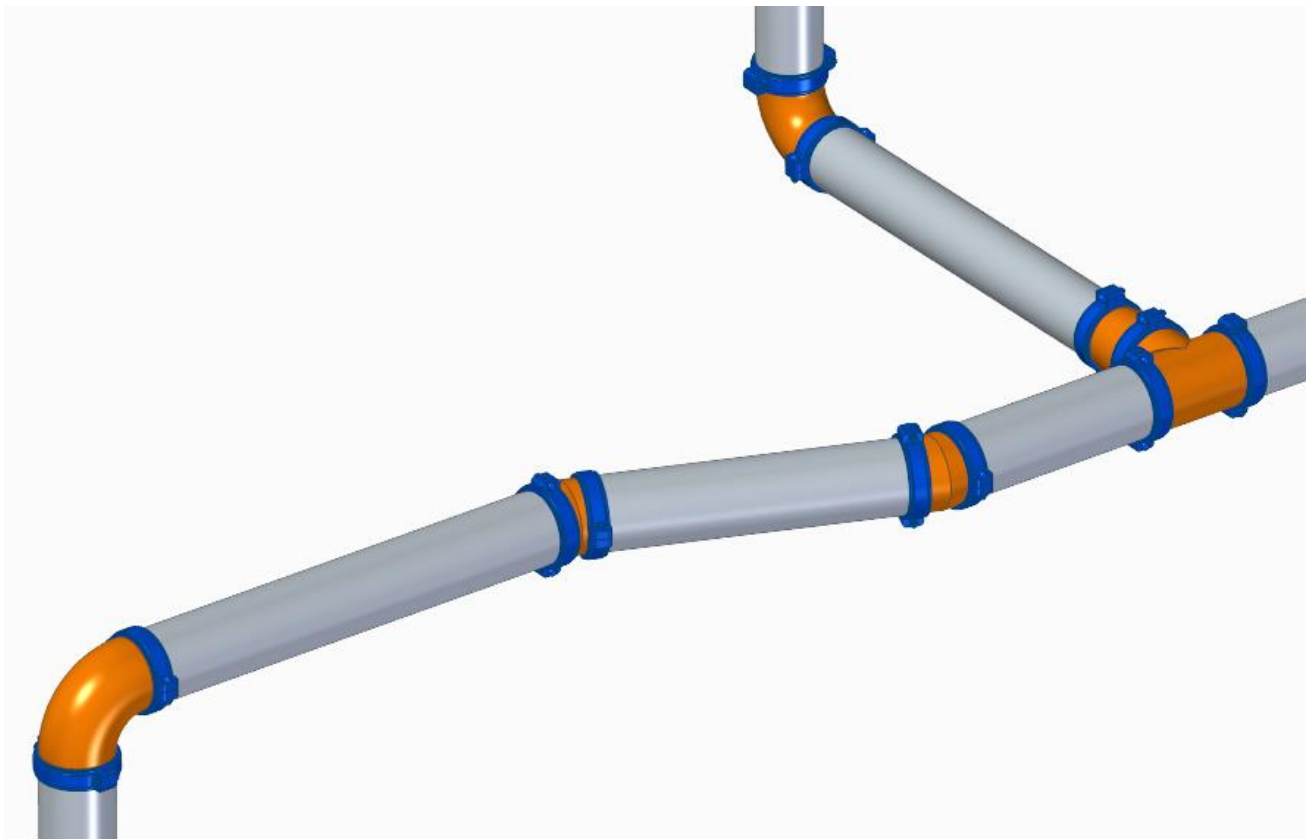

New QuickPlace method Clamp

For the automated use of clamp connection systems with Smap3D Piping, we have developed and added the new QuickPlace method (placement automation) **Clamp**.

This new automation is intended for placement of clamp connection components according to **DIN 32676**, but also manufacturer-specific clamp connection systems such as GEMO®, Heco® and others.

Unlike the automation of **Lapjoint**, a clamp demand on an existing component requires the new **ET18** end-treatment.

By using the new **Clamp** automatic placement in combination with the already existing automations (e.g. Gasket, etc.) in a pipe specification, users can quickly and fully generate complex pipelines with clamp connections with Smap3D Piping.

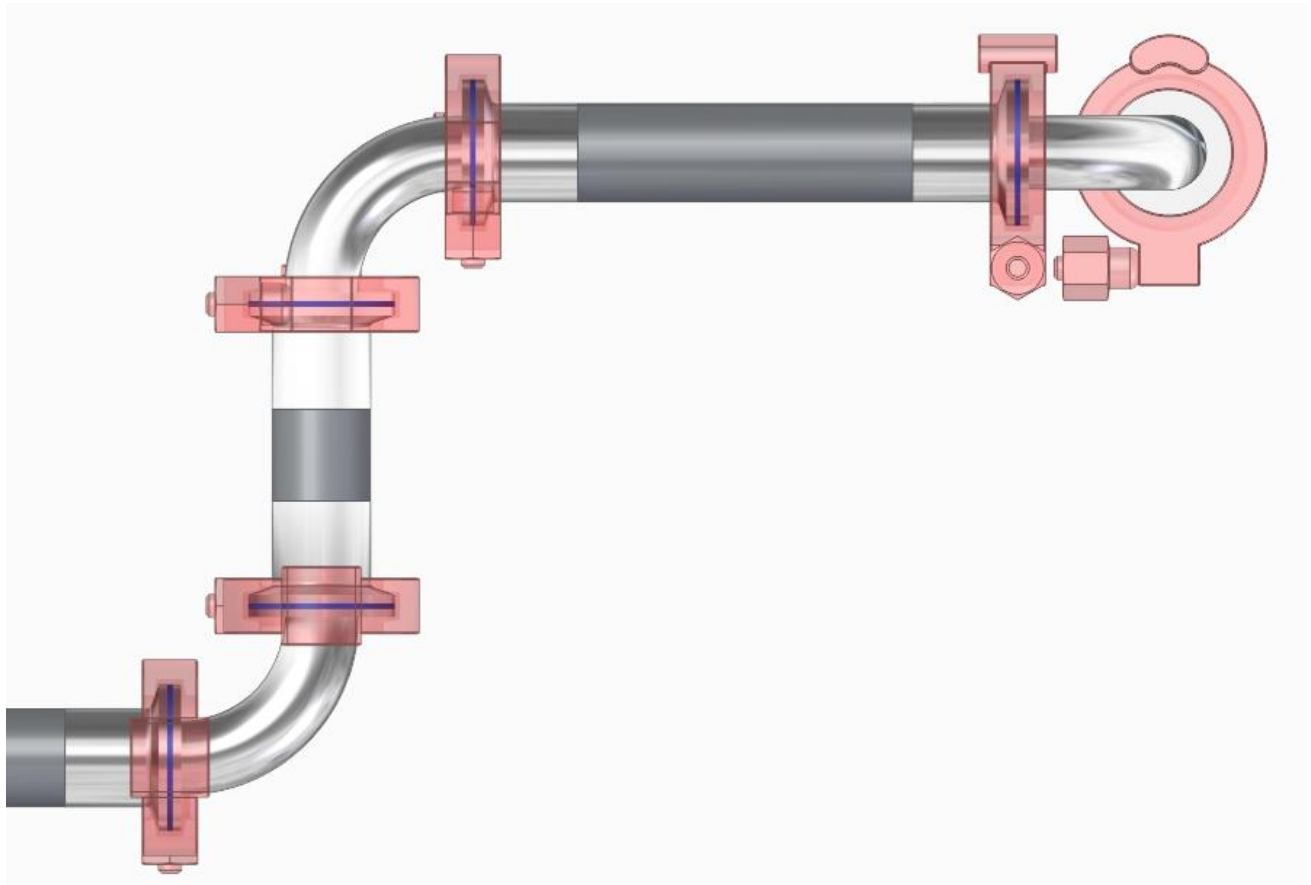

New QuickPlace methods for tube fittings

For the automated use of tube fitting components with Smap3D Piping, we have developed and added several new QuickPlace methods (placement automations).

These new automations are intended for placement of tube fitting components to **EN ISO 8434-1** through **-3**, as well as manufacturer-specific tube fitting systems as Parker®, Ermeto®, Swagelok® and others.

Typical for such tube fitting components are the different **connection variants at the component ends**.

The main distinction is between a **Spigot end** (or tapered spigot end) and a **Socket end** (or tapered socket end).

Since the development of these new methods was mainly based on the **EN ISO 8434-1 to -3** standard, our name for the QuickPlace methods is selected accordingly.

For the first time, we have **named these QuickPlace methods not after the part** that is automatically placed, **but after the part connection (cone spigot ends, cone socket ends, and red. cone spigot ends and red. cone socket ends)** to which the add-on components are automatically placed.

Our goal is to make the use of automations available to our customers as universally as possible.

QuickPlace method for cone spigot ends

The new QuickPlace method **Cone spigot ends**, places a component defined in a pipe specification under the Key name Threaded joint nipple to existing components (e.g. bends, tees, etc.), which contain the definition of **Cone spigot ends** (with **ET16** end-treatment) at a connection end. For the use cases known to us, the automatic placement of a single tube fittings component (e.g. nipple) at such connection ends is required.

Here in the picture, the defined screwed fitting nipple (brass) was automatically placed at the cone spigot end of the bend (blue transparent).

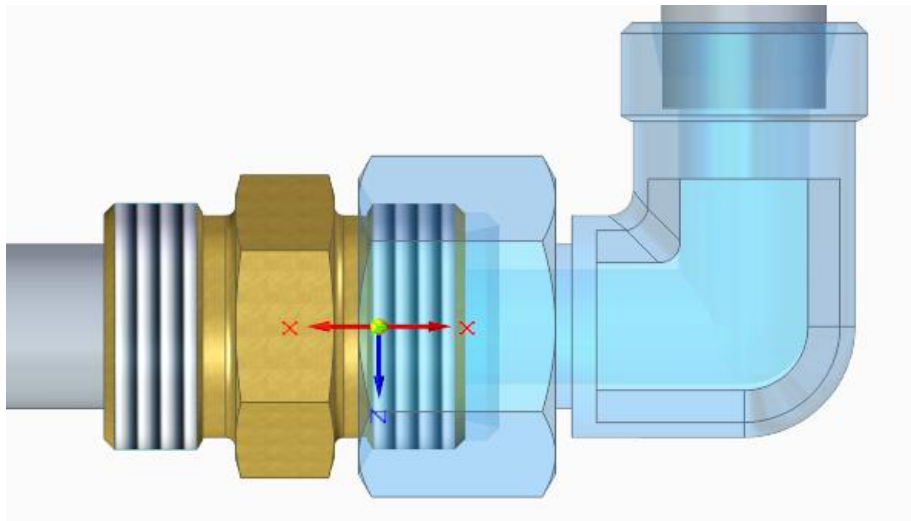

For further information on the necessary definitions for an add-on component to be placed (e.g. threaded nipple), please refer to the chapter Key name Threaded joint nipple or in the Piping 2020 software help (e.g. [Online](#)).

QuickPlace method for cone socket ends

The new QuickPlace method **Cone socket ends**, places the components defined in a pipe specification under the Key name Threaded joint socket unit to existing components (e.g. bends, tees, etc.), which contain the definition of **Cone socket ends** (with **ET15** end-treatment) at a connection end.

For the use cases known to us, the automatic placement of up to 3 individual components (e.g. welding nipple and nut) at such connection ends is required.

Here in the picture, the defined welding nipple (brass) plus nut (red transparent) was automatically placed at the cone socket end of the bend (blue transparent).

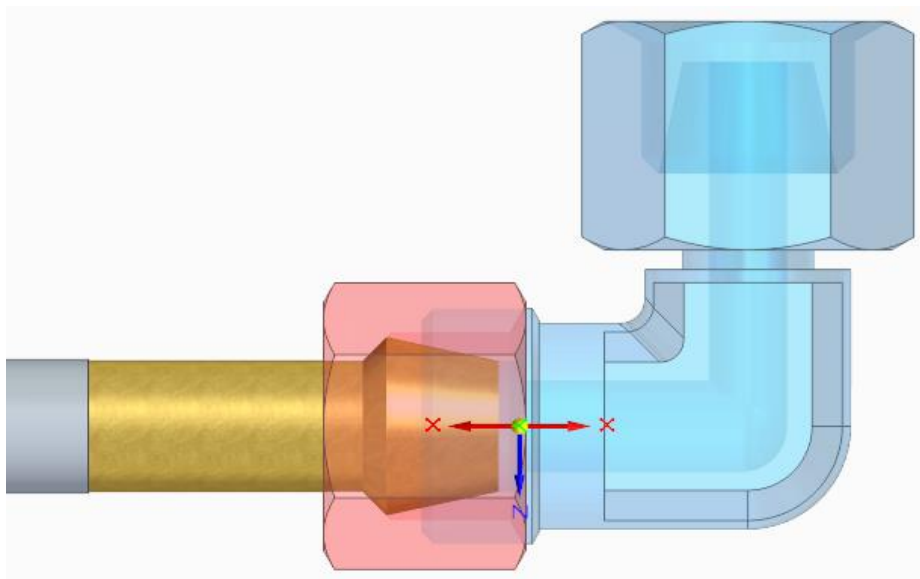

Further information on the necessary definitions for the up to 3 add-on components to be placed, can be found in the chapter Key name Threaded joint socket unit or in the Piping 2020 software help (e.g. [Online](#)).

QuickPlace method for reduced cone spigot ends

This automation will only be available in Piping with service pack 1 for Plant Design 2020.

The new QuickPlace method **Red. cone spigot ends**, places one component defined in a pipe specification under the Key name Red. threaded joint nipple, when generating a reduced pipeline with Smap3D Piping (e.g. at reduced tee situations or using the **Split route** function) always to an existing component which contains the definition **reduced cone spigot end** (with **ET16** end-treatment) at a connection end, but is placed and associated at the larger pipe diameter. In most use cases, the automatic placement of a single tube fitting (e.g. reduced nipple) at this connection end is required.

Here in the picture, the defined reduced nipple (brass) was automatically placed at the cone spigot end of the bend (blue transparent) when using **Split route** function.

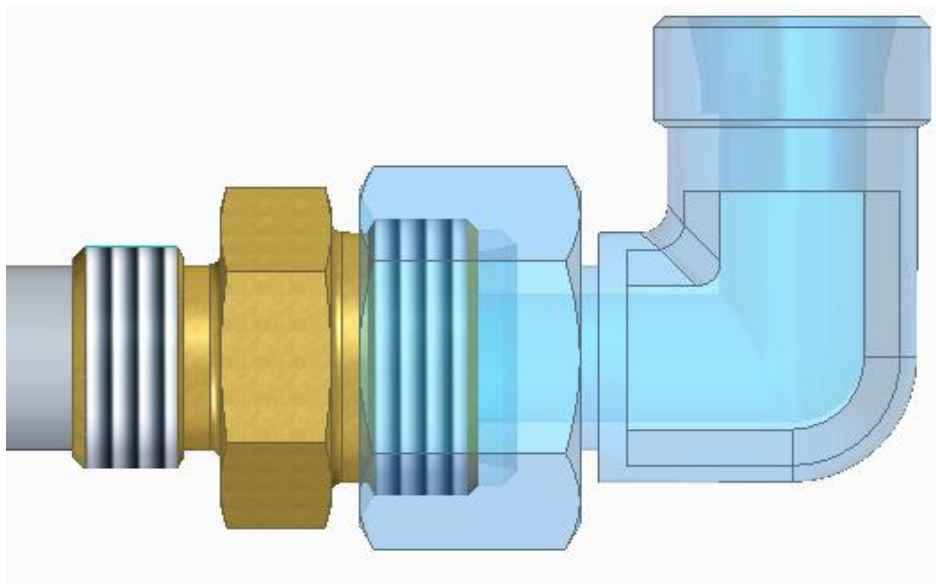

QuickPlace method for reduced cone socket ends

This automation will only be available in Piping with service pack 1 for Plant Design 2020.

The new QuickPlace method **Red. cone socket ends**, places the components (up to 3 individual components) defined in a pipe specification under the Key name Red. threaded joint socket unit, when generating a reduced pipeline with Smapi3D Piping (e.g. at reduced tee situations or using **Split route** function, always to an existing component which contains the definition **reduced cone socket ends** (with **ET15** end-treatment) at a connection end, but is placed and associated at the larger pipe diameter.

Most use cases require the automatic placement of up to 3 individual components (e.g. reduced welding nipple and nut) at this connection end.

Usually, only **component 1** is reduced. If a component 2 or a nut is necessary, it has the normal diameter as the "large" pipeline.

Here in the picture, the defined reduced welding nipple (brass) plus nut (red transparent) was automatically placed at the cone socket end of the tee (blue transparent) in a reduced tee situation.

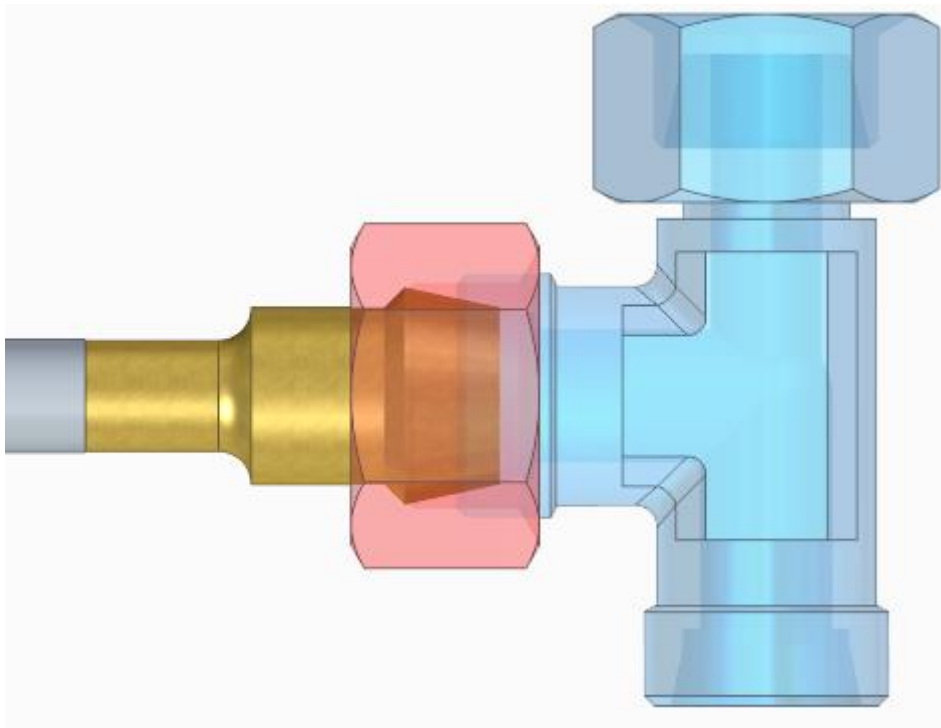

Buttons and texts renamed to Concentric Reducer

The previous name **Concentric Component** on buttons, menus, and texts has been renamed to **Concentric Reducer**.

The functions behind the buttons have **NOT** been changed.

It is still possible to process parts with reduced connections, extended connections but also connections of the same diameter.

The correct definition of the diameter (normal and reduced DN in the pipe spec) is still important.

Option to create custom pipe template

In all previous versions of Smap3D Piping, only one software-internal pipe template was used for the generation of 3D pipes in SOLIDWORKS, which could not be changed by administrators.

The new option **Use pipe template** is now available in Plant Design Administrator.

With the button **Create**, a copy of the Smap3D internal pipe template is created and saved as SOLIDWORKS template file named **SWTubeTemplate.prtdot** in the Smap3D configuration folder. Administrators can now customize this template with properties and information, according their requirements.

Changes to the given sketches, features, and equations are NOT allowed to be made, otherwise the automatic pipe generation with Piping will not work anymore!

Shape pipes can now also be placed by File System Provider

Previously, it was only possible to generate shape pipes from pipe specification with Piping, if these were defined in the pipe spec using the Part Finder (database).

If this was done via the additional standard parts provider **File System**, this did not work.

This limitation was removed with version 2020.

If a shape pipe file now contains the custom file property **PD_Shape_Tube_Length** and its value is the **name of the variable** which controls the length of the shape pipe, these parts can also be defined in a pipe specification via **File System Provider**.

If this prerequisite is fulfilled, then the generation of shape pipes in Piping also works from the File System.

Improved algorithm for add-on parts in reduced pipeline situations

In the previous versions, in special cases of pipeline generation or recalculation, the wrong size of respective add-on parts was sometimes placed in reduced situations (e.g. tee situation or conc. reduction) in connection with the additional add-on parts such as Coupling or Shape gasket or similar.

This was then always dependent on which diameter (large or reduced) the generation was started from.

In combination with the new automatic placement functions for [Clamp](#), [Grooved coupling](#), [reduced thread joint unit](#) and the **Split route** function, the corresponding algorithm has been significantly improved.

In previous problematic situations, Piping now places the necessary and correct add-on parts depending on the situation.

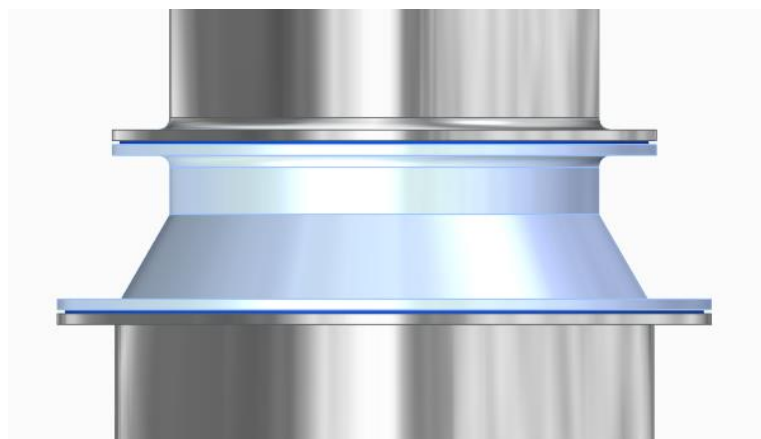
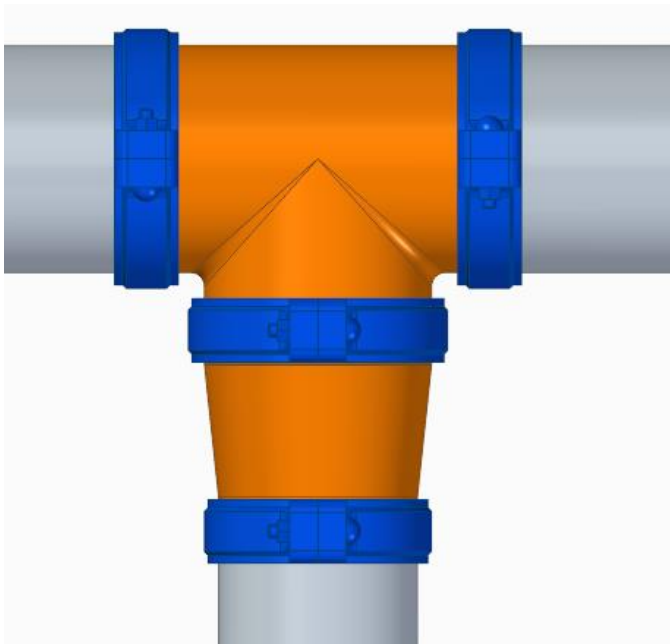

API command to rename pipeline path names from "external"

Many of our customers use PDM systems from which complete copies of existing assemblies and their subassemblies must be generated for certain functions and workflows (e.g. revision, copying, etc.).

All physically existing and copied files are renamed according to the rules/workflows of these PDM systems with corresponding PDM functions.

However, these standard PDM functions and rules cannot be applied to the pipeline paths generated by Smap3D Piping in SOLIDWORKS from the 3D-sketches, since these pipeline paths are not physical objects/files.

These pipeline paths created and named by Smap3D Piping or via the P&ID To-Do List are only stored as information within the SOLIDWORKS assembly.

In order to give customers with such PDM systems and workflows the possibility to rename the pipeline paths according to the PDM rules and workflows, new API commands were introduced for Smap3D Plant Design 2020.

These new API command work only with an **active assembly file opened in SOLIDWORKS**. They cannot be applied to closed assembly files!

For further details and a "small example program" please contact your sales partner or our support.

New in Pipe specification editor

New key name Grooved coupling

With version 2020, the new key name **Grooved coupling** with corresponding [QuickPlace method Grooved coupling](#) is available in the pipe specification editor.

i *This new key name is automatically added to existing pipe specification configuration (Common settings - PipeSpecificationCommon.pssx) during an upgrade (from PD 2019 to PD 2020 - Installation option Existing data).*

A 3D component, which is defined in a pipe spec with the key name **Grooved coupling**, is always placed on an existing component/fitting with **ET19** end-treatment when generating a pipeline with Smap3D Piping.

The basic requirements for a 3D component to be defined as a **Grooved coupling** in a pipe spec are the same as for a normal **Coupling** (details in the software help in chapter **Piping > Components for Piping**).

The only difference to a normal coupling is, that in both parts (the requesting component as well as the add-on component **Grooved coupling**), in the CSInfo of one OUTPUT_POINT coordinate system the end-treatment **Grooved coupling (ET19)** must be defined.

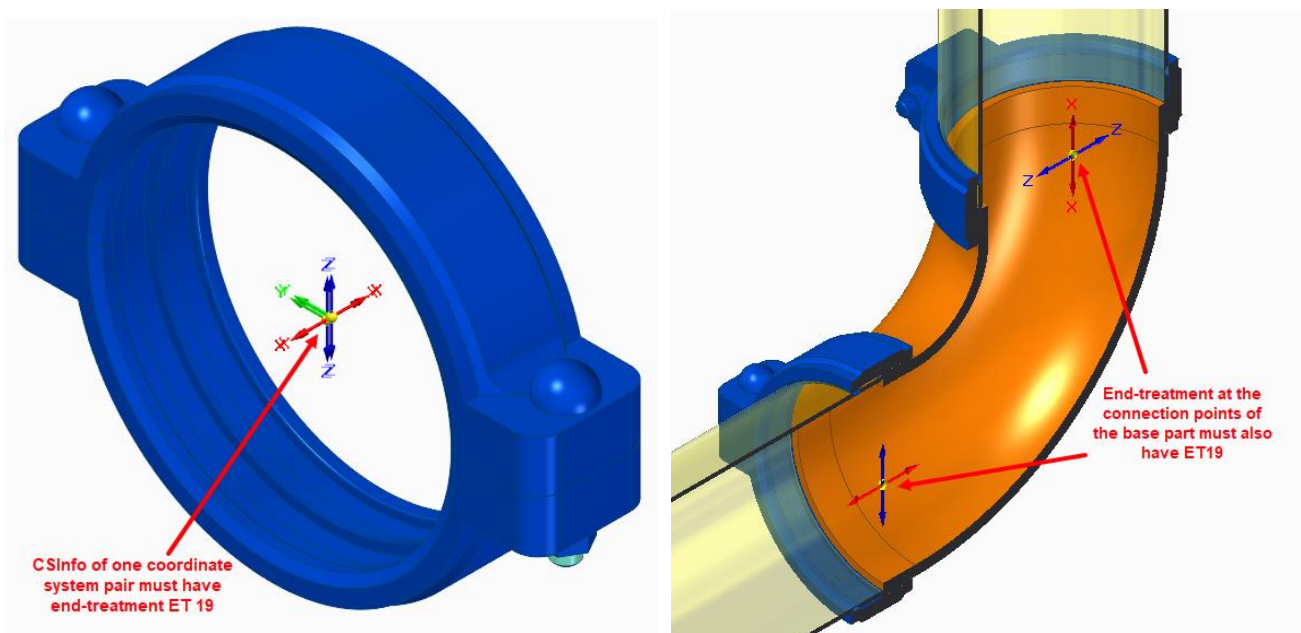

New key name Clamp

With version 2020, the new key name **Clamp** with corresponding [QuickPlace method Clamp](#) is available in the pipe specification editor.

i *This new key name is automatically added to existing pipe specification configuration (Common settings - PipeSpecificationCommon.pssx) during an upgrade (from PD 2019 to PD 2020 - Installation option Existing data).*

A 3D component, which is defined in a pipe spec with the key name **Clamp**, is always placed on an existing component/fitting with **ET18** end-treatment when generating a pipeline with Smap3D Piping.

The basic requirements for a 3D component to be defined as a **Clamp** in a pipe spec are the same as for a **Lapjoint** (details in the software help in chapter **Piping > Components for Piping**).

The only difference to a Lapjoint is, that in both parts (the requesting component as well as the add-on component **Clamp**), in the CSInfo of one OUTPUT_POINT coordinate system the end-treatment **Tri-Clamp Coupling (ET18)** must be defined.



New key names for tube fittings

With version 2020, the new key names **Threaded joint nipple**, **Threaded joint socket unit**, **Red. threaded joint nipple** and **Red. threaded joint socket unit** with corresponding [QuickPlace methods for tube fittings](#) are available in the pipe specification editor.

i *This new key names are automatically added to existing pipe specification configuration (Common settings - PipeSpecificationCommon.pssx) during an upgrade (from PD 2019 to PD 2020 - Installation option Existing data)*

Key name Threaded joint nipple

A 3D component, which is defined in a pipe spec with the key name **Threaded joint nipple**, is always placed on an existing component/fitting with **Cone spigot ends (ET16)** when generating a pipeline with Smap3D Piping.

The basic requirements for a 3D component to be defined as a **Threaded joint nipple** in a pipe specification are the same as for **flow-through components** (details in the software help in chapter **Piping > Components for Piping**).

In addition to these basic requirements, in the component for **Threaded joint nipple** one of the OUTPUT_POINT coordinate systems in the CSInfo must be defined with the end-treatment **Cone spigot ends (ET15)**.

Key name Threaded joint socket unit

With the key name **Threaded joint socket unit** up to 3 different 3D components can be defined in a pipe specification.

When generating a pipeline with Smapp3D Piping, these are always placed on an existing component/fitting with **Cone socket ends (ET15)** end-treatment.

Component	Size	End-treatment	Part Name
Threaded joint socket unit	20	-	
Component 1	20	-	Connector ISO 8434-1 - CR - S20 - ...
Component 2	20	-	
Nut	20	-	Connector ISO 8434-1 - N - S20 - br...

The basic requirements for the respective 3D components depend on the position of the **Threaded socket unit** at which this component is to be defined in a pipe spec.

- For a **Component 1**, the end-treatment **Cone spigot ends (ET16)** must always be defined for one of the OUTPUT_POINT coordinate systems and its CSInfo.
- For a **Component 2**, it depends on the relation in which this component is to be placed to component 1.
- A **Nut** component must then contain the basic definitions of Lapjoint components (details in the software help in chapter **Piping > Components for Piping**).

Due to the generally held implementation of this automation, all (or at least most) of the applications knows to us from practice in the field of tube fittings should be automated with it.

Key name Red. threaded joint nipple

This new key name is already implemented with Plant Design 2020.

However, the corresponding automation ([QuickPlace method](#)) will only be available in the software with service pack 1 for Plant Design 2020.

A 3D component, which is defined in a pipe specification with the key name **Red. threaded joint nipple**, is always placed to an existing component/fitting with end-treatment **Cone spigot end (ET16)** when generating a reduced pipeline with Smapp3D Piping (e.g. at reduced tee situations or when using the **Split route** function), starting from the larger pipeline diameter.

The basic requirements are the same as for the components for the key name **Threaded joint nipple**, where the 2nd connection point has a reduced diameter compared to the 1st connection point.

Key name **Red. threaded joint socket unit**

This new key name is already implemented with Plant Design 2020.

However, the corresponding automation ([QuickPlace method](#)) will only be available in the software with service pack 1 for Plant Design 2020.

With the key name **Red. threaded joint socket unit**, up to 3 different 3D components can be defined in a pipe spec, just as with threaded joint socket unit.

When generating a reduced pipeline with Smapp3D Piping (e.g. at reduced tee situations or when using the **Split route** function), these are always placed on an existing component/fitting with **Cone socket end (ET15)** end-treatment, starting from the larger pipe diameter.

As a typical use case, **Component 1** is reduced (e.g. reduced welding nipple as shown). Component 2, which may be necessary, and a nut have the normal diameter like the large pipeline.

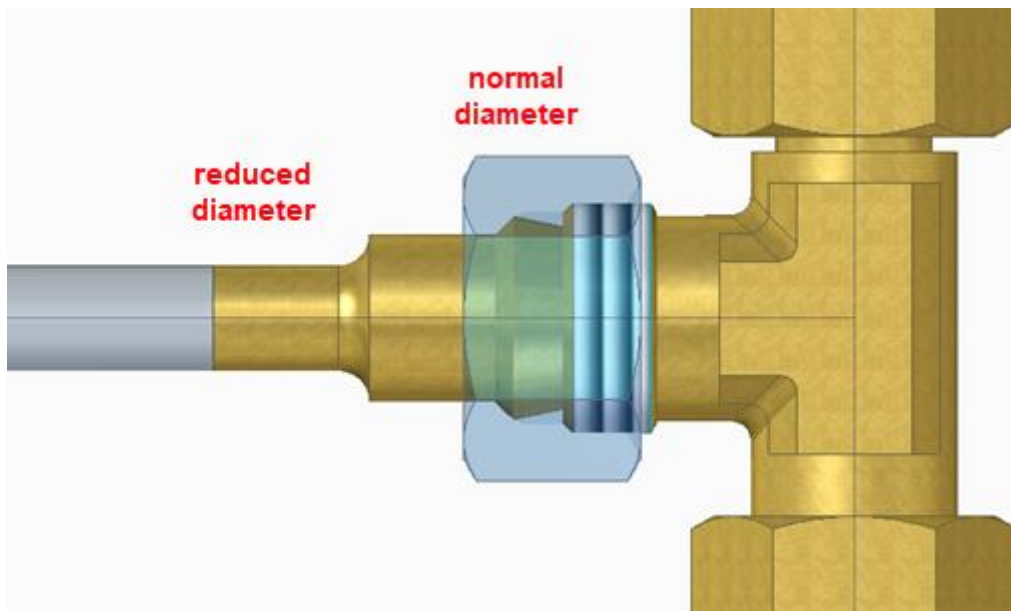

New option to control the standard setting for "Use favorites"

The **Use favorites** option is now available in **Options** tab of the pipe specification editor. The settings can be made **Global** or individually for each **Diameter**.

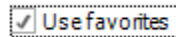

With this new option in pipe specification editor, an administrator can now preset and save the preferred option of the **Use favorites** option when working with a pipe specification in Smap3D Piping.

Until now, this option was only available for a user working with pipe specification in Piping and had to be switched by the user as required.

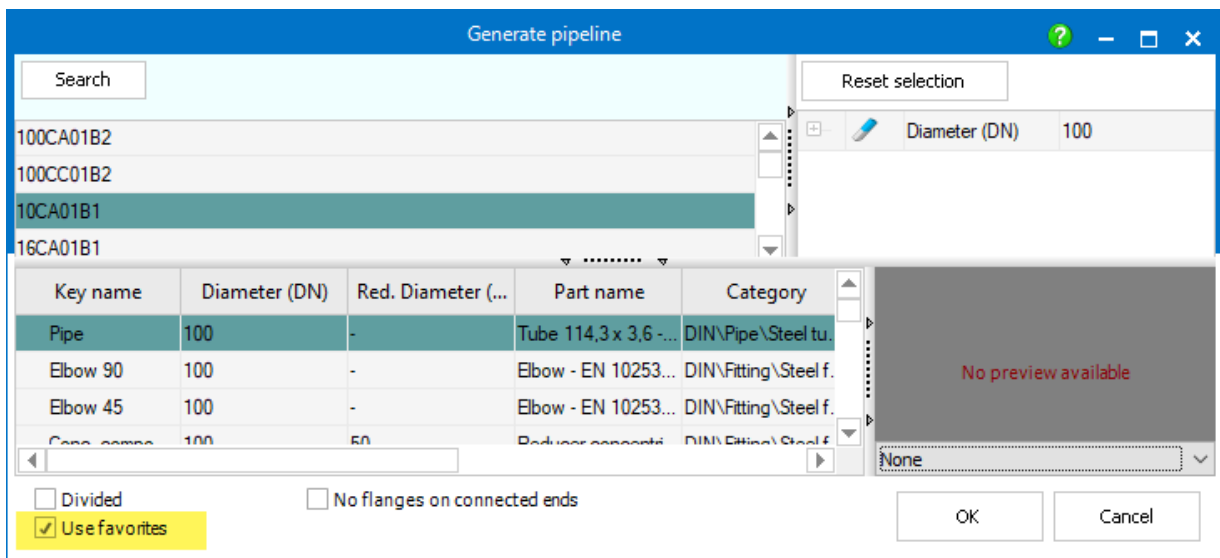

New in the P&ID To-Do list

Redesign of analysis algorithms when loading PRO files

Due to problems and limitations reported by customers in various customer-specific use cases with To-Do list, we had to redesign and redevelop the analysis algorithms in their core function

The most important results achieved by the redesign are as follows:

Result: significantly accelerated loading times for very large PRO files.

By redesigning the analysis algorithms, we were able to greatly speed up loading times when loading assigned PRO files.

The more extensive the content of an assigned PRO file, the higher the acceleration factor.

Examples from our test results:

- If it took about 60 seconds to load a PRO file into v2019, the v2020 only needs 45 seconds to do so.
- A PRO file that took v2019 about 3 minutes to complete display, it takes about 1.5 minutes with v2020.
- And an extremely large PRO file, which took about 10 minutes to load in v2019, is now displayed in about 3 minutes with all contents in the To-Do list.

Result: extended plausibility checks during loading

Since missing and incorrect information on the P&ID components and pipelines can lead to problems in the To-Do list and when generating the 3D pipelines, we have refined the plausibility checks during loading process and the corresponding messages more detailed.

This should help the user to understand the most logical errors in the P&ID diagram more easily and to correct them in P&ID before working in 3D.

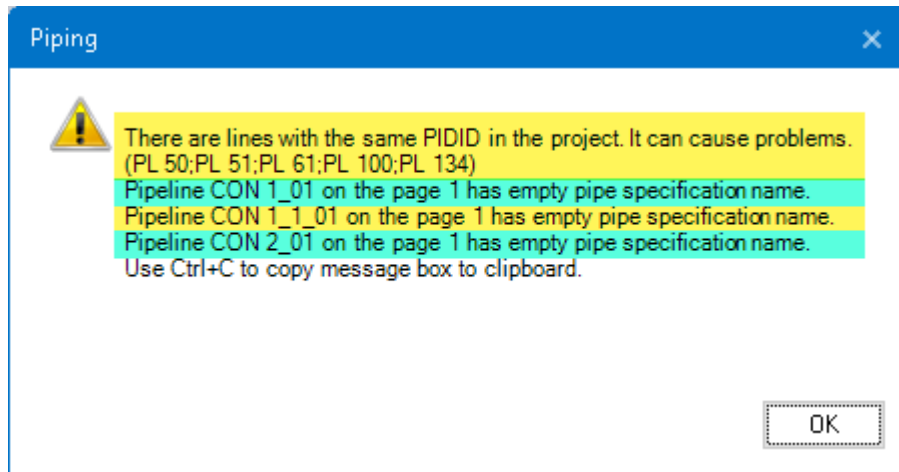

Result: Improvement for pipelines across multiple diagram pages

P&ID lines (lines with identical names and attributes) that ran across multiple diagram pages, where previously displayed as one line per page in To-Do list.

This diagram page related analysis and representation was completely removed, so that now a line, no matter over how many diagram pages this runs, is shown in the To-Do list as one line, because during the realization in a 3D assembly only one line with this name and properties will be generated.

Further news in To-Do list

The redesign of the core algorithms mainly used the available development capacities for P&ID To-Do list.

Nevertheless, our development not only managed to remove errors and limitations, but also add new and very helpful functions for the users!

Separate buttons for "Route" functions

The route functions introduced with Piping 2019 are also available and important when using the To-Do list.

When working with To-Do list, the **Create route**, **Auto Route**, **Manual Route** and **Edit route** functions were previously only available in the context menu.

When using the Piping buttons of the same name, this led to error messaged in special cases.

To prevent this in the future, these buttons are integrated into the toolbar of the To-Do list adapted to the use with the To-Do list.

New items for displaying as columns and for filtering

In the **P&ID To-Do list options** new properties were added, which can be used as display columns and then to filter the To-Do list content.

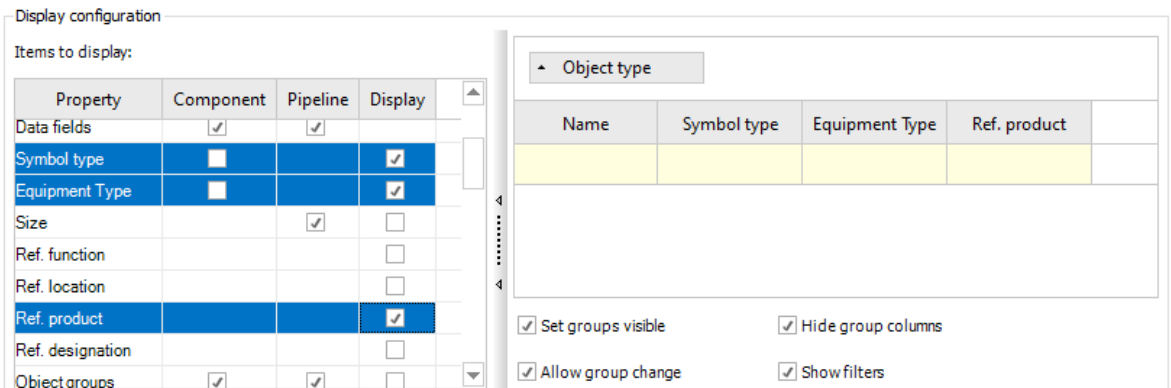

Symbol type

If the property **Symbol type** is used, the respective value of the P&ID symbol is displayed for the components in the To-Do list and can be filtered.

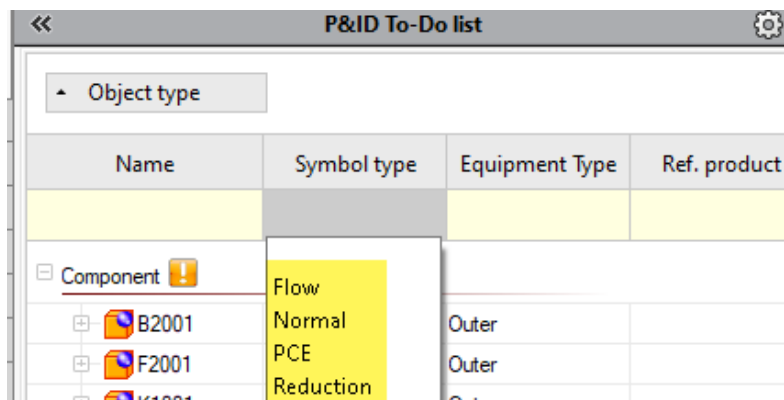
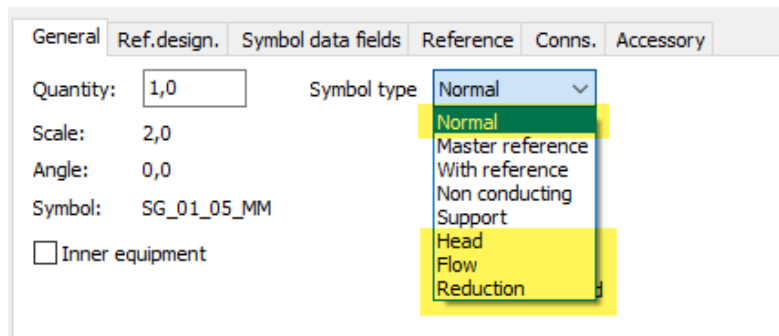

Equipment type

When using the **Equipment type** property, the respective value of the P&ID symbol is displayed for components in the To-Do list and can be filtered.

If the Inner Equipment checkbox is set in the P&ID symbol, the value in the To-Do list is **Inner**.
 If the check is not set, the value in the To-Do list is **Outer**.

General Ref.design. Symbol data fields Reference Conns. Accessory

Quantity: 1,0 Symbol type Normal

Scale: 2,0

Angle: 0,0

Symbol: SG_01_05_MM

Inner equipment

Visible

Physical

Conduction

Name protected

<< P&ID To-Do list >>

Object type

Name	Symbol type	Equipment Type	Ref. product
Component			
B2001	Normal	Inner Outer	
F2001	Normal	Outer	

Ref. product

When using the property **Ref. product** for components in the To-Do list, the respective defined value of the P&ID symbol is displayed when using a reference designation from the aspect product and it can be filtered on it.

Name	Symbol type	Equipment Type	Ref. product
<div style="border: 1px solid gray; padding: 2px;"> [-] Component </div>			
F2001	Normal	Outer	
K1001	Normal	Outer	
-P1.B2001	Normal	Outer	P1
P2000	Flow	Outer	

New in Smapp3D Isometric

Support of the ISOGEN function Revision Clouds

For the representation of revision clouds in an isometric drawing on components or pipelines, the option for the **Revision Clouds** are available in ISOGEN style with **output format DWG** (configured via I-Configure).

For ISOGEN styles whose output format is set to DXF, these revision clouds are not supported.

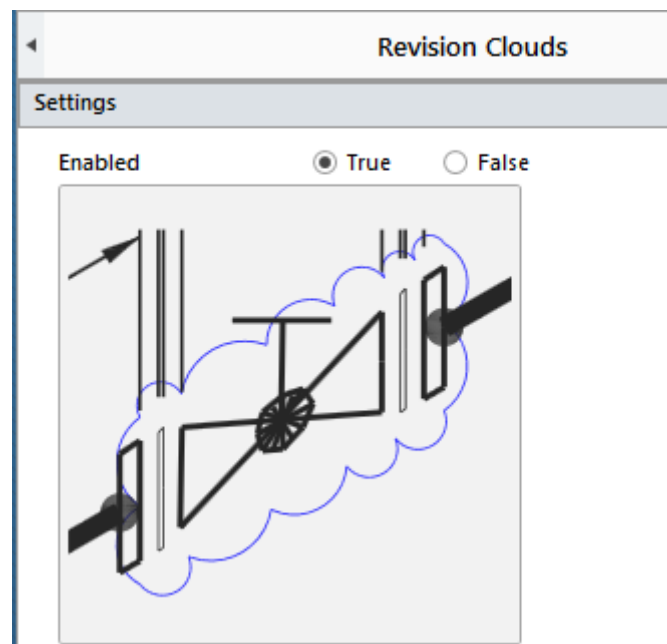

The prerequisite for this representation in an isometric drawing is the transfer of suitable information to the PCF feature **REVISION**.

As source of this **REVISION** information, **all known possibilities are available on CAD side**. The most important for a correct result is the correct allocation of the information source as **CAD feature** to the **PCF feature**.

In the following example the Smapp3D **VC Writer** was used as information source on the CAD side. With the VC Writer the information **REVISION** with the value **R1** is transferred to the 3D model in the 3D assembly.

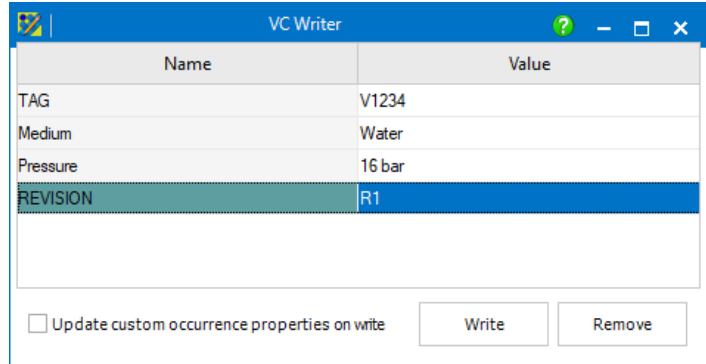
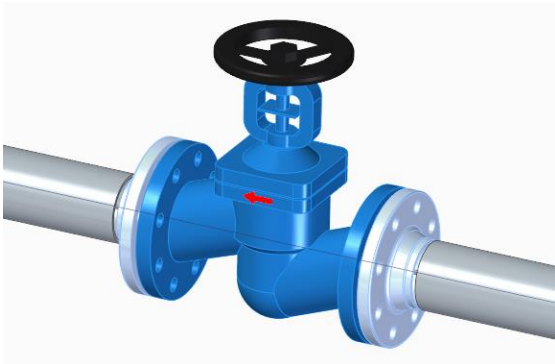

In the Smapp3D Isometric **Step 2**, this information is read from the 3D model and listed.

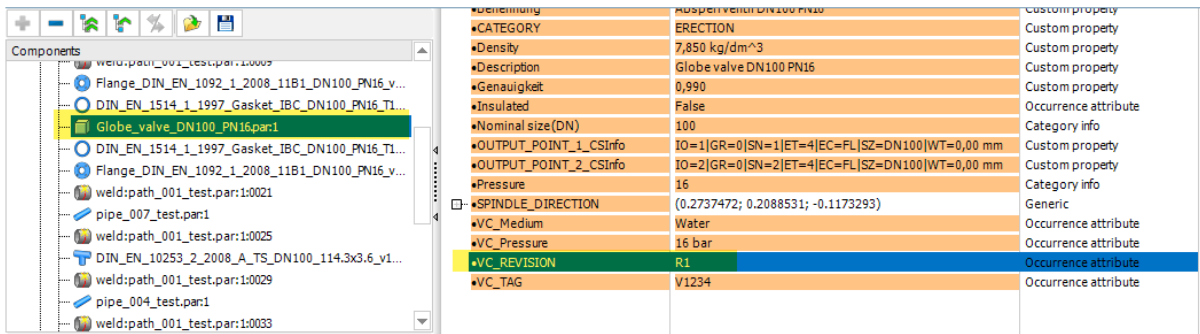

By correctly assigning the information source used in the Isometric options, tab **Output mappings**, this information is transferred to ISOGEN.

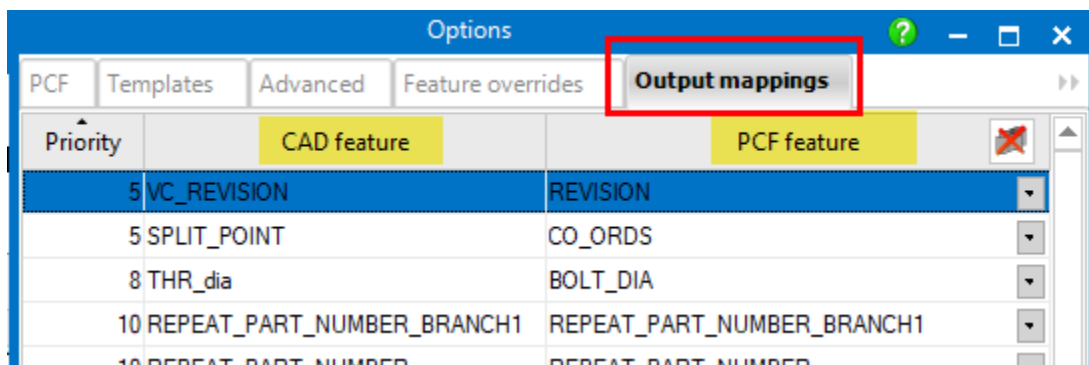

The representation on the generated isometric drawing then takes place according to the detail settings in the used ISOGEN style with **output format DWG** (configured via the I-Configure).

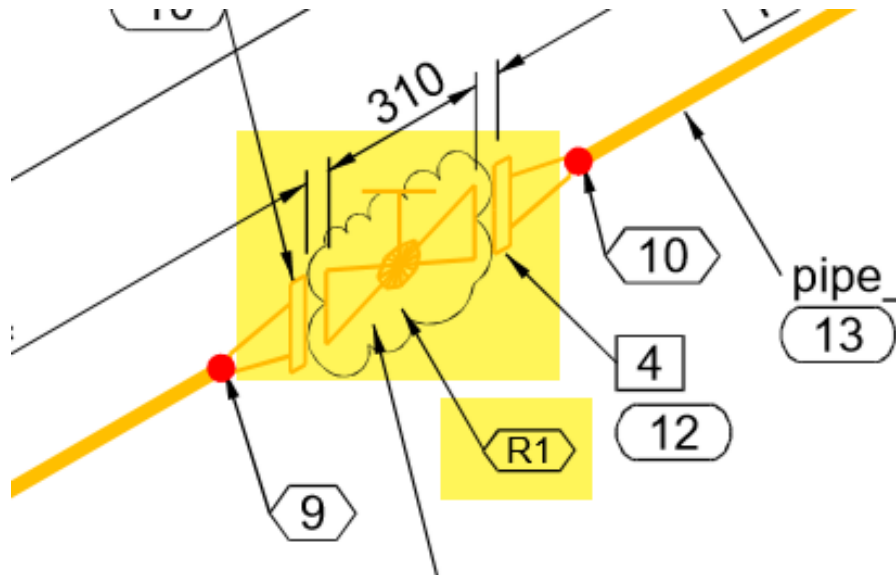

Support of the ISOGEN Weld attributes

For the special transfer and display of weld attributes on an isometric drawing, the **Weld Attribute 1 to-99** can now also be used.

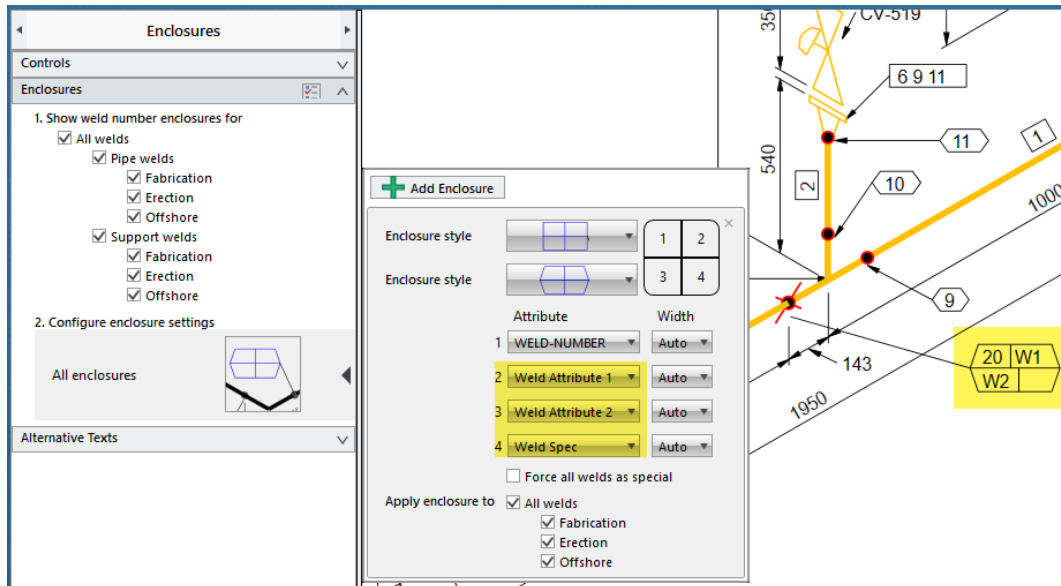

These can now be found in the Isometric options, tab **Output mappings**, in the **PCF feature** column.

PCF	Templates	Advanced	Feature overrides	Output mappings
Priority	CAD feature		PCF feature	
5	SPLIT_POINT	CO_ORDS		
5	w_att_2	WELD_ATTRIBUTE2		
5	w_att_1	WELD_ATTRIBUTE1		
8	THR_dia	WELD_ATTRIBUTE10		
10	ANGLE	WELD_ATTRIBUTE11		
10	REPEAT_PART_NUMBER_BRA...	WELD_ATTRIBUTE12		
10	REPEAT_PART_NUMBER	WELD_ATTRIBUTE13		
10	Raw_PCF	WELD_ATTRIBUTE14		
10	RATING	WELD_ATTRIBUTE15		
10	PLATE_THICKNESS	WELD_ATTRIBUTE16		
10	PLATE DIRECTION	WELD_ATTRIBUTE17		
		WELD_ATTRIBUTE18		
		WELD_ATTRIBUTE19		
		WELD_ATTRIBUTE20		
		WELD_ATTRIBUTE21		

Also, here it is the most important for a correct result, to make the correct assignment of the information source as **CAD feature** to the **PCF feature**.

Support of PDF output according to ISOGEN style settings

For an ISOGEN style (configured via I-Configure) there is the possibility to activate an automatic PDF creation in addition to the standard format DWG.

For ISOGEN styles whose output format is set to DXF, no PDF will be created.

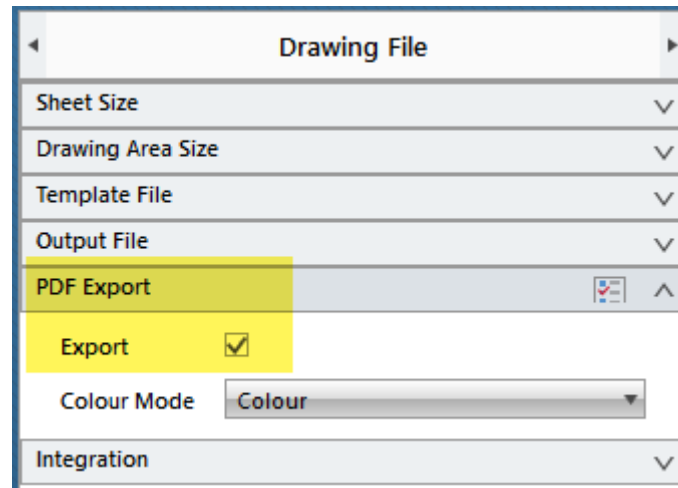

All relevant information and communications are now transferred from Smap3D Isometric to ISOGEN.

As result (if this is activated in the used style with DWG output), ISOGEN creates parallel to the drawing in the **output format DWG** an additional PDF file.

Pipeline_1_Iso_Final-Weld-Box.DWG	08.11.2019 15:42
Pipeline_1_Iso_Final-Weld-Box.mes	08.11.2019 15:42
Pipeline_1_Iso_Final-Weld-Box.pdf	08.11.2019 15:42

New custom CAD property "IgnoreInIsometric" to improve reading performance

In many situations where isometric creation is started over an entire assembly structure (many different sub-assembly structures) the reading speed (from step 1 to step 2) is often longer than expected by the user.

This is often due to complex sub-assembly structures that need to be analyzed by Isometric to create the correct isometric drawings.

In all cases, in which such substructures do not contain any pipeline relevant components (e.g. frame or rack assemblies, or also separate equipment assemblies with further subassembly structures), this analysis time is used in vain.

Smap3D Isometric could not "recognize" such situations before, but always had to examine all assembly structures and levels for pipeline relevant contents.

With the new possibility to define the user-defined property **IgnoreInIsometric** with the value **true** or **yes** in not isometric relevant CAD assemblies, the reading process can be accelerated considerably in such cases.

For all arbitrary, but not Isometric relevant assemblies (with further subassembly structures), this new property should be defined on the main/highest assembly level.

If you start the reading process in Smap3D Isometric, this property is recognized, and any further analysis of the contained substructure is skipped.

This dramatically increases the reading speed for assemblies with many such "irrelevant assembly contents" compared to version 2019.



Smap3D Plant Design GmbH

Am Marktplatz 7
93152 Nittendorf
Germany

Phone.: +49 9404 9639-10
Fax: +49 9404 5209

info@smap3d.com
www.Smap3D.com

© 2019 Smap3D Plant Design GmbH. All rights reserved.

These documentations respectively training materials are copyrighted works.
The copyrights belong solely to Smap3D Plant Design GmbH.
Reproduction, publication, modification or translation - also in the form of excerpts -
is not allowed without the express permission of Smap3D Plant Design GmbH.
The information in these documents is subject to change without notice
and does not constitute an obligation on the part of Smap3D Plant Design GmbH.
The content has been carefully checked.
However, Smap3D Plant Design GmbH assumes no liability for any errors or omissions.

Smap3D is a Trademark of CAD Partner GmbH. All other names,
registered trademarks and product names are used herein are the
property of their respective holders.